

CENTRAL PLATTE VALLEY COORDINATION METROPOLITAN DISTRICT
8390 E. CRESCENT PKWY., STE. 300
GREENWOOD VILLAGE, CO 80111
Phone: 303-779-5710 Fax: 303-779-0348
www.cpvcmd.org

NOTICE OF REGULAR MEETING AND AGENDA

DATE: Tuesday, May 7, 2024
TIME: 9:00 a.m.

LOCATION: DaVita Inc.
 2000 16th Street
 Denver, CO 80202

You can also attend the meeting in any of the following ways:

A. To attend via MS Teams videoconference, use the link below:

ACCESS: https://teams.microsoft.com/l/meetup-join/19%3ameeting_MzJIYzkyOWEtYWM2My00NDMzLWEzY2MtZGJNTVjMzlwZWMx%40thread.v2/0?context=%7b%22Tid%22%3a%224aaa468e-93ba-4ee3-ab9f-6a247aa3ade0%22%2c%22Oid%22%3a%22d42bab28-fbd8-4e65-a395-965cf9ef152f%22%7d

B. To attend via telephone, dial 1-720-547-5281
 Enter the following Conference ID: 745 383 16#

<u>Board of Directors</u>	<u>Office</u>	<u>Term Expires</u>
Jason Dorfman	President	May 2027
Michael Geiger	Secretary	May 2025
Derrick Walker	Treasurer	May 2025
Amy Cara	Assistant Secretary	May 2025
Jordan Kind	Assistant Secretary	May 2025

I. ADMINISTRATIVE MATTERS

- A. Call to order and approval of agenda.
- B. Present disclosures of potential conflicts of interest.
- C. Confirm quorum, location of meeting and posting of meeting notices.
- D. Public comment.

Members of the public may express their views to the Board on matters that affect the District that are otherwise not on the agenda. Comments will be limited to three (3) minutes per person.

II. CONSENT AGENDA

- A. Review and consider approval of the Minutes of the April 2, 2024 Regular Meeting (enclosure).
- B. Accept March 31, 2024 Unaudited Financial Statements and Cash Position Report (enclosure).
- C. Approval of May 2024 Checks Totaling \$134,164.82 (enclosure).
- D. Review March 2024 Monthly Security Report from DDP BID (enclosure).
- E. Approval of 17th Street Gardens Fence Design (enclosure).
- F. Ratify Approval of DesignScapes Change Order for Rough Cedar to Garden Beds - \$3,300 (enclosure).

III. MANAGER ITEMS

- A. 17th Street Gardens follow up.
- B. Update on Projects.
- C. Nine Dot Arts Roadmap Presentation.
- D. Review Maintenance Coordination Report – EWUM, Brandon Fries (enclosure).
 - 1. Update on Hello Darling permit process.
- E. Update on Holiday Lighting (enclosures).
- F. Tree Planting Phase II Update.

IV. FINANCIAL ITEMS

V. PROJECT UPDATES

VI. DIRECTOR ITEMS

VII. ATTORNEY ITEMS

VIII. OTHER BUSINESS

IX. ADJOURNMENT

The next regular meeting is scheduled for Tuesday, June 4, 2024 at 9:00 a.m. at DaVita Inc. (2000 16th Street, Denver, CO 80202) and via MS Teams

RECORD OF PROCEEDINGS

MINUTES OF A REGULAR MEETING OF THE BOARD OF DIRECTORS OF THE CENTRAL PLATTE VALLEY COORDINATION METROPOLITAN DISTRICT (THE “DISTRICT”)

APRIL 2, 2024

A regular meeting of the Board of Directors of the Central Platte Valley Coordination Metropolitan District (referred to hereafter as the “Board”) was convened on Tuesday, April 2, 2024, at 9:00 a.m. at Davita, 2000 16th Street, Denver, CO 80202 and via WebEx videoconference. The meeting was open to the public.

ATTENDANCE

Directors In Attendance Were:

Jason Dorfman, President
Derrick Walker, Treasurer
Michael Geiger, Secretary
Jordan Kind, Assistant Secretary

Amy Cara, Assistant Secretary was absent and excused.

Also In Attendance Were:

Anna Jones, Shauna D’Amato, Jason Carroll and Jenna Trujillo;
CliftonLarsonAllen LLP
Dianne Miller, Esq., Rhonda Bilek and Sonja Steele; Miller & Associates Law
Offices, P.C.
Brandon Fries; East West Urban Management
Cole Kralik; Allied Universal
John Tryba; WSP
Downtown Denver Partnership (DDP); Savina Valencia Chavez

ADMINISTRATIVE MATTERS

Call to Order and Agenda: Director Dorfman called the meeting to order at 9:04 a.m. Upon a motion duly made by Director Geiger, seconded by Director Walker and, upon vote, unanimously carried, the Board approved the agenda, as presented and excused the absence of Director Cara.

Disclosures of Potential Conflicts of Interest: Attorney Miller advised the Board that, pursuant to Colorado law, certain disclosures by the directors may be appropriate prior to taking official action at the meeting and that written disclosures of the interests of all directors were filed with the Secretary of State and the District prior to the meeting. The Directors then reviewed the agenda for the meeting and previous written disclosures stating the fact and summary nature of any matters, as required under Colorado law, to permit official action to be taken at the meeting.

RECORD OF PROCEEDINGS

Quorum, location of meeting, and posting of meeting notice: It was noted that a quorum was present allowing the Board to act on all matters to come before them at this meeting. The Board confirmed the location of the meeting and the posting of the meeting notice.

Public comment: None

CONSENT AGENDA

**Minutes of the March 5, 2024 Special Meeting:
February 29, 2024 Unaudited Financial Statements and Cash Position
Report:
Interim Checks Totaling \$234,682.94:
February 2024 Monthly Security Report from DDP BID:**

Following review, upon a motion duly made by Director Geiger, seconded by Director Walker and, upon vote, unanimously carried, the Board approved and accepted the Consent Agenda items, as presented.

MANAGER ITEMS

Review Maintenance Coordination Report – EWUM, Brandon Fries: Mr. Fries reviewed his report with the Board.

Hello Darling Permit Process: Mr. Fries informed the Board that Hello Darling is actively going through the permitting process with the City.

Approval of Artificial Turf on Wewatta Street:

- **DCPS Landscaping - \$6,666.11:**
- **Turfscapes of Colorado - \$7,739.15:**

Mr. Fries reviewed each proposal with the Board explaining the current “pet relief” areas located on Wewatta Street. He indicated that the synthetic turf will allow for the urine to dissipate downward through the synthetic turf. The maintenance of a topical cleanser and pressure washing will eliminate unwelcome smells. Following review, upon a motion duly made by Director Walker, seconded by Director Kind and, upon vote, unanimously carried, the Board approved the Turfscapes of Colorado proposal in the amount of \$7,739.15 for artificial turf on Wewatta Street.

Mr. Fries mentioned that TKE completed the elevator repair, but did not complete the inspection of the door closures. This will be inspected by the City of Denver.

17th Street Gardens:

RECORD OF PROCEEDINGS

1. **Update on Projects:** Mr. Tryba provided updates to the Board noting that the tier two application is completed with all permits being approved. The tier three application is almost complete and awaiting storm water approval. .

WSP Project Oversight: Mr. Tryba reviewed the inspection proposal with the Board noting these services would provide inspections for the 17th St. Gardens Project, specifically on public safety, stormwater compliance, and work installation per plans & specs. Following review and discussion, upon a motion duly made by Director Geiger, seconded by Director Walker and, upon vote, unanimously carried, the Board approved the inspection proposal in the amount of \$10,264.00, as presented.

Update on Phase II Tree Planting: Ms. D'Amato provided a status update to the Board stating that Save-A-Tree has begun scheduling the installation of the second phase of tree replacements.

Nine Dot Arts Update: Ms. D'Amato provided an update to the Board informing the Board of the workshop that was held in late March. She also shared that for those members of the Board that were not in attendance, the slides from the meeting are available for review and comment

Update on Holiday Lighting: Ms. D'Amato informed the Board of holiday lighting updates, stating that Xcel is unable to accommodate the additional outlets on their poles within the District. She informed the Board that she has investigated other holiday lighting alternatives and will provide more information at the May meeting. The Board would like to pursue Xcel and Attorney Miller mentioned she has additional contacts there.

Update on Music Concepts: Ms. D'Amato provided an update to the Board noting that in addition to the summer music series, a holiday music series could be of interest. The Board directed staff to obtain a proposal for the May meeting for their review and consideration

Area Wide Event Planning and Communications: Ms. D'Amato provided an update to the Board informing the Board that CLA is in the process of coordinating events with Union Station and other Districts in the vicinity to provide the residents and occupants information on the event schedules throughout the area.

FINANCIAL ITEMS

None.

RECORD OF PROCEEDINGS

PROJECT UPDATES None.

DIRECTOR ITEMS None.

ATTORNEY ITEMS None.

OTHER BUSINESS A quorum was confirmed for the May 7, 2024 meeting at 9:00 a.m. and was noted this will now be conducted by MS Teams, and no longer on WebEx.

ADJOURNMENT There being no further business to come before the Board at this time, upon a motion duly made by Director Walker, seconded by Director Geiger and, upon vote, unanimously carried, the Board adjourned the meeting at 10:08 a.m.

Respectfully submitted,

Secretary for the Meeting

CPV COORDINATION METROPOLITAN DISTRICT

FINANCIAL STATEMENTS

MARCH 31, 2024

**Central Platte Valley Coord Metro Dist
Balance Sheet - Governmental Funds
March 31, 2024**

	General	Total
Assets		
Checking Account	\$ 92,696.18	\$ 92,696.18
Due from Other Districts	271,000.00	271,000.00
Accounts Receivable	37,919.13	37,919.13
Total Assets	\$ 401,615.31	\$ 401,615.31
Liabilities		
Accounts Payable	\$ 366,134.57	\$ 366,134.57
Event Deposits	1,500.00	1,500.00
Total Liabilities	367,634.57	367,634.57
Fund Balances	33,980.74	33,980.74
Liabilities and Fund Balances	\$ 401,615.31	\$ 401,615.31

No assurance is provided on these financial statements. Substantially all required disclosures, the government-wide financial statements, and the statement of revenues, expenditures and changes in fund balances - governmental funds have been omitted.

Central Platte Valley Coord Metro Dist
General Fund Statement of Revenues, Expenditures and Changes in
Fund Balances - Budget and Actual
For the Period Ending March 31, 2024

	<u>Annual Budget</u>	<u>Actual</u>	<u>Variance</u>
Revenues			
Intergovernmental Revenues	\$ 2,850,000.00	\$ 455,963.07	\$ 2,394,036.93
Transfers from other districts - Capital	350,000.00	-	350,000.00
Total Revenue	<u>3,200,000.00</u>	<u>455,963.07</u>	<u>2,744,036.93</u>
Expenditures			
General government			
Accounting	85,000.00	22,836.48	62,163.52
Auditing	5,000.00	-	5,000.00
Contingency	11,542.00	-	11,542.00
Directors' fees	6,000.00	1,100.00	4,900.00
District management	125,000.00	35,132.21	89,867.79
Dues and membership	4,500.00	1,237.50	3,262.50
Insurance	7,500.00	6,834.00	666.00
Legal	55,000.00	7,346.50	47,653.50
Miscellaneous	3,000.00	268.38	2,731.62
Onsite Management	120,000.00	20,112.27	99,887.73
Payroll taxes	458.00	-	458.00
Professional services - PR and communication	18,000.00	-	18,000.00
Operations and maintenance			
Landscaping and other maintenance	800,000.00	49,986.31	750,013.69
17th Street Gardens	365,000.00	21,898.83	343,101.17
Security	700,000.00	166,388.64	533,611.36
Millennium Bridge maintenance	285,000.00	37,245.13	247,754.87
Union Gateway Bridge maintenance	205,000.00	87,424.83	117,575.17
Engineering - repairs and maintenance	50,000.00	-	50,000.00
Capital			
Art Funds	350,000.00	43,031.00	306,969.00
Total Expenditures	<u>3,196,000.00</u>	<u>500,842.08</u>	<u>2,695,157.92</u>
Net Change in Fund Balances	4,000.00	(44,879.01)	48,879.01
Fund Balance - Beginning	13,644.00	78,859.75	(65,215.75)
Fund Balance - Ending	<u>\$ 17,644.00</u>	<u>\$ 33,980.74</u>	<u>\$ (16,336.74)</u>

No assurance is provided on these financial statements. Substantially all required disclosures, the government-wide financial statements, and the statement of revenues, expenditures and changes in fund balances - governmental funds have been omitted.

SUPPLEMENTARY INFORMATION

CENTRAL PLATTE VALLEY COORDINATION METROPOLITAN DISTRICT
Schedule of Cash Deposits & Investments
March 31, 2024
Updated as of April 25, 2024

	<u>General Fund</u>
<u>Wells Fargo Bank - Checking Account</u>	
Balance as of 03/31/24	\$ 92,696.18
Subsequent activities:	
04/03/24 Denver Water ACH	(250.73)
04/03/24 Transfer from CPVMD	255,000.00
04/04/24 Vouchers payable	(248,160.45)
04/05/24 Xcel ACH	(4,452.28)
04/16/24 CenturyLink ACH	(250.80)
Anticipated transfer from CPVMD	95,036.93
Anticipated vouchers payable	(134,164.82)
<i>Anticipated Balance</i>	<u><u>\$ 55,454.03</u></u>

No assurance is provided on these financial statements. Substantially all required disclosures, the government-wide financial statements, and the statement of revenues, expenditures and changes in fund balances - governmental funds have been omitted.

Central Platte Valley Coordination Metropolitan District - General Fund									
Schedule of Maintenance Costs									12
				2023	2024	3/31/24	2024	Budget	
				Actual	Budget	Actual	Estimated	Variance	
Acct No.	Account Name:	Vendor/Description	Notes						
107606		Denver Police - Off Duty (RPA)		296,641	360,000	68,958	360,000	-	
		DDPBID Security		271,679	260,000	55,544	260,000	-	
		Stealth Monitoring		72,470	70,000	18,650	70,000	-	
		Additional Security		-	10,000	183	10,000	-	
				640,790	700,000	143,335	700,000	-	
	Landscaping and Other Maintenance								
107585	Landscaping and repairs	DCPS/Genesis	Annual contract	108,914	90,000	38,041	90,000	-	
107584			DDBID	-	40,000	-	40,000	-	
107584		Landscaping - Tree maintenance		91,978	120,000	-	120,000	-	
107586		Landscaping - Tree replacement		8,223	10,000	-	10,000	-	
107586		Other - Irrigation and other repairs							
107587	Lighting	Xcel	Pedestrian lights	15,365	20,000	3,209	20,000	-	
107588	General maintenance/cleanup	DDPBID	Base contract	188,117	260,000	-	260,000	-	
		Other	Encore	-	25,000	-	25,000	-	
107593		Snow removal	DDBID	4,202	40,000	-	40,000	-	
107589	Irrigation	Denver Water		6,784	6,000	590	6,000	-	
107590	Fossil filters	Komac	Base contract - 55% to District	39,720	30,000	7,017	30,000	-	
		Komac	Replacement	-	20,000	-	20,000	-	
107592	Storm drainage	Annual storm drainage	2 locations	3,440	5,000	1,129	5,000	-	
107591	Other	Gallegos/MGT/Encore	Granite repairs/electrical	42,398	50,000	-	50,000	-	
		Seasonal/Holiday Lighting		-	80,000	-	80,000	-	
		Contingency		-	4,000	-	4,000	-	
				509,141	800,000	49,986	800,000	-	
	17th Street Gardens								
107810	Landscaping	Landscape design/renovations	Includes temporary fencing	95,000	95,000	11,557	95,000	-	
		Denver Commercial Property Services - annual contract		30,000	30,000	-	30,000	-	
107812	Repairs and maintenance	DDBID		80,000	80,000	10,049	80,000	-	
		Other repairs and maintenance	Orkin/stantec	40,000	40,000	257	40,000	-	
		Seasonal lighting		12,000	12,000	-	12,000	-	
107820		Activation		30,000	30,000	-	30,000	-	
107815		Other	Musicians	75,000	75,000	-	75,000	-	
107811	Irrigation	Denver Water	35% of 1678 Chestnut Place	3,000	3,000	36	3,000	-	
				365,000	365,000	21,899	365,000	-	

No assurance is provided on these financial statements. Substantially all required disclosures, the government-wide financial statements, and the statement of revenues, expenditures and changes in fund balances - governmental funds have been omitted.

Central Platte Valley Coordination Metropolitan District - General Fund									
Schedule of Maintenance Costs									13
				2023	2024	3/31/24	2024	Budget	
				Actual	Budget	Actual	Estimated	Variance	
Acct No.	Account Name:	Vendor/Description	Notes						
	Millennium Bridge/Mall/Fountain								
107601	General Maintenance/Cleanup	EWUM/RPA		55,022	65,000	15,003	65,000	-	
		DDPBID - Bridge maintenance		43,395	55,000	15,791	55,000	-	
		Other		-	1,000	-	1,000	-	
107602	Elevator	ThyssenKrupp	Maintenance contract	10,812	12,000	1,865	12,000	-	
		ThyssenKrupp	Other repairs	16,367	25,000	-	25,000	-	
		Other repairs	Gallegos/RPA	2,872	2,500		2,500	-	
		JT Specialty Services	Graffiti	3,794	5,000	400	5,000	-	
		Long Mechanical		9,374	6,000	(984)	6,000	-	
		Reflection Windows	Housing glass cleaning	6,000	10,000	1,500	10,000	-	
		Fire Alarm system		4,014	7,000	-	7,000	-	
		Integra phone charges		540	4,000	627	4,000	-	
		Elevator permits/inspections		-	1,500	-	1,500	-	
107603	Lighting	Xcel	16th Street A&B - Power to bridge	15,640	16,000	2,801	16,000	-	
107604	Irrigation	16th Street Fountain		4,808	3,000	125	3,000	-	
		Promenade Lofts/Western Proscapes		745	2,500	-	2,500	-	
107605	Snow removal	DDPBID		-	15,000	-	15,000	-	
107609	Other	68 West - Bridge maintenance		-	-	-	-	-	
		Landscaping		-	10,000	-	10,000	-	
		Encore Electric/Mathias/Connect		-	10,000	117	10,000	-	
		Fountain repair/deck repairs		-	5,000	-	5,000	-	
		Gallegos/Stantec/Commercial Lighting		12,884	20,000	-	20,000	-	
		Millennium Bridge inspection		-	-	-	-	-	
		Wood refinishing	Railing and benches	-	-	-	-	-	
		Bridge painting		-	-	-	-	-	
		Contingency		-	9,500	-	9,500	-	
				186,267	285,000	37,245	285,000	-	

No assurance is provided on these financial statements. Substantially all required disclosures, the government-wide financial statements, and the statement of revenues, expenditures and changes in fund balances - governmental funds have been omitted.

Central Platte Valley Coordination Metropolitan District - General Fund									
Schedule of Maintenance Costs									14
				2023	2024	3/31/24	2024	Budget	
				Actual	Budget	Actual	Estimated	Variance	
Acct No.	Account Name:	Vendor/Description	Notes						
	Union Gateway Bridge								
107701	General Maintenance/Cleanup	EWUM		48,711	60,000	15,448	60,000	-	
		DDPBID - Bridge maintenance		33,694	50,000	7,897	50,000	-	
		Other		466	2,000	-	2,000	-	
107702	Elevator	Century Link		3,995	5,000	1,024	5,000	-	
		ThyssenKrupp	Maintenance contract	10,440	13,000	2,701	13,000	-	
		ThyssenKrupp	Other repairs	47,217	20,000	45,823	20,000	-	
		JT Specialty	Graffiti	3,130	3,000	390	3,000	-	
		Long Mechanical		870	5,000	-	5,000	-	
		Reflection Windows	Housing glass cleaning	6,000	7,000	1,500	7,000	-	
		Elevator permits/inspections		-	1,000	600	1,000	-	
		Fire Alarm system		540	1,500	1,044	1,500	-	
		Other	American Mechanical Services	400	1,500	2,449	3,000	(1,500)	
107703	Lighting	Xcel		22,021	27,000	8,549	27,000	-	
107704	Other	Other repairs	Encore	-	4,000	-	4,000	-	
		68 West - Bridge maintenance		-	-	-	-	-	
		Contingency		-	5,000	-	5,000	-	
				177,484	205,000	87,425	206,500	(1,500)	
				1,878,682	2,355,000	339,890	2,356,500	(1,500)	
				(118,150)	50,000				
		DDPBID		708,863	880,000	89,281	880,000	-	
		Denver Commercial Property Services		138,914	130,000	38,041	130,000	-	
		EWUM/RPA		103,733	125,000	30,451	125,000	-	
		68 West		-	-	-	-	-	
		ThyssenKrupp		84,836	70,000	50,389	70,000	-	
		JT Specialty		6,924	8,000	790	8,000	-	
		Long Mechanical		10,244	11,000	(984)	11,000	-	
		Reflection Windows		12,000	17,000	3,000	17,000	-	
		Gallegos		55,282	70,000	-	70,000	-	
		Livable Cities/MGT		95,000	95,000	11,557	95,000	-	

No assurance is provided on these financial statements. Substantially all required disclosures, the government-wide financial statements, and the statement of revenues, expenditures and changes in fund balances - governmental funds have been omitted.

**CENTRAL PLATTE VALLEY COORDINATION METROPOLITAN DISTRICT
2024 BUDGET
SUMMARY OF SIGNIFICANT ASSUMPTIONS**

Services Provided

The District, a quasi-municipal corporation and a political subdivision of the State of Colorado, was organized by order and decree of the District Court for the County of Denver on February 19, 2013 and is governed pursuant to provisions of the Colorado Special District Act (Title 32, Article 1, Colorado Revised Statutes). The District's service area is located in the City and County of Denver (City). The District operates under a Service Plan approved by the City Council on November 26, 2012.

The District was organized to implement a multi-district structure to more effectively accommodate both residential and commercial development within and without the District's physical boundaries.

On February 5, 2013, the District's voters authorized the District to collect, retain, and spend the full amount of all taxes, tax increment revenues, tap fees, park fees, facility fees, service charges, inspection charges, administrative charges, grants or any other fee, rate, toll, penalty, or charges authorized by law or contract to be imposed, collected or received by the District during 2013 and each fiscal year thereafter, such amounts to constitute a voter-approved revenue change and be collected, retained and spent by the District without regard to any spending, revenue-raising, or other limitation.

The District has no power to issue any debt and no authority to impose a mill levy upon any property within or without its boundaries. Rather, the primary source of revenue available to the District is based upon its ability to enter into inter-governmental agreements with other governmental entities (IGAs). The basic nature of these IGAs would be for a governmental entity with taxing or other revenue-generating authority, such as the Central Platte Valley Metropolitan District (CPV MD) to transfer revenues to the District, which would then use the funds to provide for the operation and maintenance of all of the improvements and the provision of public services not otherwise dedicated to third party entities.

In accordance with its Service Plan, the District is entirely responsible for coordinating the operation and maintenance of all public services and improvements throughout the development. It is anticipated that all capital improvements will be owned and maintained by CPV MD or dedicated to the City or to such other governmental entity as appropriate.

The District has no employees, and all administrative functions are contracted.

The District prepares its budget on the modified accrual basis of accounting in accordance with the requirements of Colorado Revised Statutes C.R.S. 29-1-105 using its best estimates as of the date of the budget hearing. These estimates are based on expected conditions and its expected course of actions. The assumptions disclosed herein are those that the District believes are significant to the budget. There will usually be differences between the budget and actual results, because events and circumstances frequently do not occur as expected, and those differences may be material.

**CENTRAL PLATTE VALLEY COORDINATION METROPOLITAN DISTRICT
2024 BUDGET
SUMMARY OF SIGNIFICANT ASSUMPTIONS**

Revenues

Intergovernmental Revenue

On October 8, 2013, the District entered into an intergovernmental agreement (IGA) with Central Platte Valley Metropolitan District (CPV MD). Per this Agreement, payments from CPV MD represent transfers from CPV MD to the District to provide funding for the overall administrative and operating costs for both Districts, as well as to pay administrative capital costs.

During 2024, it is anticipated that the District will receive \$3,200,000 from CPV MD - \$2,850,000 will be used for general government, operations and maintenance expenditures, and \$350,000 will be used for administrative capital costs.

Expenditures

Administrative and Operational Expenditures

Administrative expenditures include the services necessary to maintain the District's administrative viability such as accounting and audit, engineering, insurance, legal, management, and meeting expenses. Operational expenditures in 2024 include the security and maintenance of areas within the District and the excluded area, including the 17th Street Gardens, Union Gateway Bridge and the Millennium Bridge, fountain, and elevators. These expenditures are based on estimates of the District's Board of Directors and consultants.

Capital Expenditures

The 2024 anticipated capital expenditures include amounts for art funds within CPV MD as detailed on page 1 of the budget.

Debt and Leases

The District has no outstanding debt nor any capital or operating leases.

Reserves

Emergency Reserve

TABOR requires local governments to establish Emergency Reserves. These reserves must be at least 3% of fiscal year spending. Since all funds received by the District are transferred from CPV MD, an emergency reserve is not reflected in the District's 2024 Budget. Therefore, the Emergency Reserve related to the District's revenue is reported in CPV MD.

Central Platte Valley Coordination Metropolitan District
 Schedule of Payables as of April 25, 2024
 Paid May 7, 2024

Vendor	Invoice #	Date	Approval Status	Payment Status	Open Balance	
1 Above Elevator Inspections	184-24	3/28/2024	Approving	Unpaid	\$ 600.00	
1 Above Elevator Inspections	220-24	4/11/2024	Approving	Unpaid	200.00	800.00
American Mechanical Services of Denver, LLC	1376216	3/26/2024	Approving	Unpaid	2,449.35	2,449.35
Century Link	303-436-9655MAR24	3/4/2024	Approving	Unpaid	250.80	
Century Link	303-629-6990658B0APR	4/4/2024	Approving	Unpaid	90.95	341.75
CliftonLarsonAllen LLP	L241201822	3/31/2024	Approving	Unpaid	11,673.67	11,673.67
Denver Commercial Property Services	2000	4/1/2024	Approving	Unpaid	3,220.95	
Denver Commercial Property Services	2122	4/11/2024	Approving	Unpaid	393.58	3,614.53
DENVER WATER	0592267648APR24	4/10/2024	Approving	Unpaid	18.40	
DENVER WATER	4661150000APR24	4/10/2024	Approving	Unpaid	18.40	
DENVER WATER	8291430350APR24	4/10/2024	Approving	Unpaid	18.40	
DENVER WATER	3804050000APR24	4/10/2024	Approving	Unpaid	41.58	
DENVER WATER	4987054226APR24	4/10/2024	Approving	Unpaid	142.15	
DENVER WATER	8489380088APR24	4/10/2024	Approving	Unpaid	18.40	257.33
Diversified Underground Inc	29438	3/31/2024	Approving	Unpaid	40.00	40.00
Downtown Denver BID	SEC39249-24-3/15/24-3/28/24	4/2/2024	Approving	Unpaid	9,857.42	
Downtown Denver BID	SEC39356-24-3/28/24-4/11/24	4/16/2024	Approving	Unpaid	9,560.62	19,418.04
East West Urban Management	3/31 UG	3/31/2024	Approving	Unpaid	4,493.50	
East West Urban Management	3/31 MB	3/31/2024	Approving	Unpaid	4,298.21	
East West Urban Management	03/31 Mgmt	3/31/2024	Approving	Unpaid	6,749.76	15,541.47
Encore Electric	72101	3/29/2024	Approving	Unpaid	117.00	
Encore Electric	72100	4/12/2024	Approving	Unpaid	2,639.00	2,756.00
JT Specialty Services	21938	4/12/2024	Approving	Unpaid	555.00	555.00
Livable Cities Studio, Inc	2173	3/25/2024	Approving	Unpaid	3,365.00	3,365.00
LONG Building Technologies, Inc	SCPAY0068976	4/10/2024	Approving	Unpaid	984.00	984.00
Miller and Associates Law Offices	1074	3/31/2024	Approving	Unpaid	2,605.00	2,605.00
Reflection Windows & Doors LLC	94511	3/22/2024	Approving	Unpaid	500.00	
Reflection Windows & Doors LLC	94512	3/22/2024	Approving	Unpaid	500.00	
Reflection Windows & Doors LLC	94738	4/12/2024	Approving	Unpaid	500.00	
Reflection Windows & Doors LLC	94739	4/12/2024	Approving	Unpaid	500.00	2,000.00
Riverfront Park Association	Allstream 03/11/24-04/10/24	3/13/2024	Approving	Unpaid	211.37	
Riverfront Park Association	SEC3/04/24-3/18/24	3/19/2024	Approving	Unpaid	14,865.00	
Riverfront Park Association	9960061452 Verizon	4/1/2024	Approving	Unpaid	32.77	
Riverfront Park Association	SEC3/18/24-3/31/24	4/2/2024	Approving	Unpaid	13,196.25	
Riverfront Park Association	SEC4/01/24-4/14/24	4/16/2024	Approving	Unpaid	12,197.50	
Riverfront Park Association	Allstream 04/11/24-05/10/24	4/16/2024	Approving	Unpaid	260.17	40,763.06
Stealth Monitoring Inc	IN381083	3/15/2024	Approving	Unpaid	560.00	
Stealth Monitoring Inc	IN382233	4/9/2024	Approving	Unpaid	5,750.00	6,310.00
TK Elevator Corporation	6000708654	2/27/2024	Approving	Unpaid	5,697.69	
TK Elevator Corporation	3007752821	3/1/2024	Approving	Unpaid	932.41	
TK Elevator Corporation	3007811028	4/1/2024	Approving	Unpaid	2,797.25	
TK Elevator Corporation	3007811123	4/1/2024	Approving	Unpaid	2,701.38	
TK Elevator Corporation	5002429844	4/3/2024	Approving	Unpaid	522.20	
TK Elevator Corporation	6000717213	4/11/2024	Approving	Unpaid	3,256.13	15,907.06
Utility Notification Center of Colorado	224030330	3/31/2024	Approving	Unpaid	10.32	10.32
Wastewater Management Division	02332-21-549-000MAR24	3/22/2024	Approving	Unpaid	1,016.01	
Wastewater Management Division	02332-21-550-000MAR24	3/22/2024	Approving	Unpaid	112.57	1,128.58
Xcel Energy	53-2026712-7APR24	4/1/2024	Approving	Unpaid	812.48	
Xcel Energy	53-2026711-6APR24	4/11/2024	Approving	Unpaid	867.70	
Xcel Energy	53-9105366-2APR24	4/11/2024	Approving	Unpaid	1,816.94	
Xcel Energy	53-0010034496-2APR24	4/11/2024	Approving	Unpaid	147.54	3,644.66
Grand Total					<u>\$ 134,164.82</u>	<u>\$ 134,164.82</u>

No assurance is provided on these financial statements. Substantially all required disclosures, the government-wide financial statements, and the statement of revenues, expenditures and changes in fund balances - governmental funds have been omitted.

Allied Universal Security Report

Safety	Mar 1st-31st	YTD
Aggressive Panhandling	0	0
Assault	0	1
Disturbance	28	82
Injury/Illness	0	3
Park Curfew Violation	0	0
Public Intoxication	0	2
Public Urination	0	0
Public Use of Drugs	5	10
Trespass	30	63
Unauthorized Camping	18	41
Vandalism	17	40
Totals	98	242

Ambassador	Mar 1st-31st	YTD
Assistance (Directions/Info)	74	175
Business Checks	428	1182
Lost property	0	0
Positive Comment	0	6
Totals	502	1363

Outreach	Mar 1st-31st	YTD
Welfare Check	66	205

Safety	242
Ambassador	1363
Outreach	205

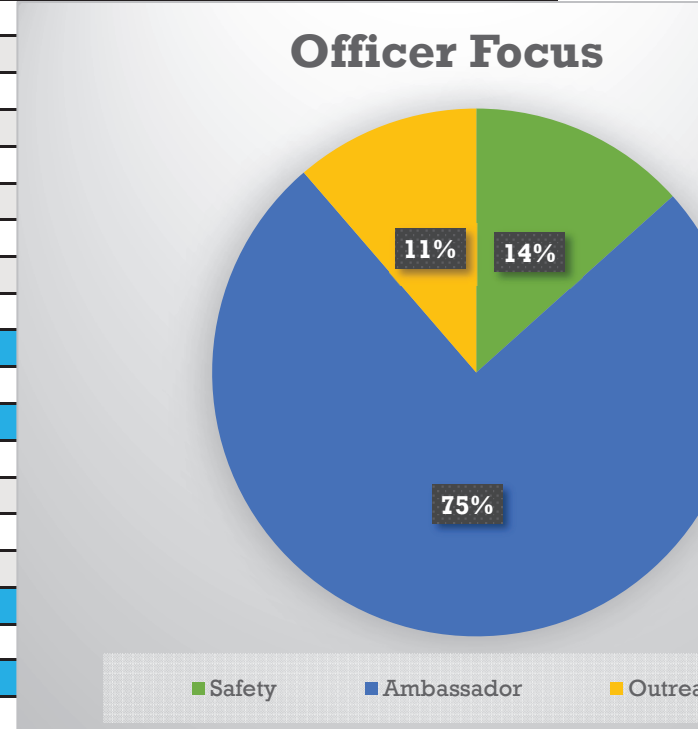

3/1/2024

Allied Universal Security Report

Tracking Spreadsheet

Incident Response	Jan 1st-31st	Feb 1st-29th	Mar 1st-31st																	Monthly Total	Monthly Average
Aggressive Panhandling	0	0	0																	0	0
Assault	1	0	0																	1	0
Disturbance	20	34	28																	82	27
Injury/Illness	2	1	0																	3	1
Park Curfew Violations	0	0	0																	0	0
Public Intoxication	0	2	0																	2	1
Public Urination	0	0	0																	0	0
Public Use of Drugs	4	1	5																	10	3
Trespass	14	19	30																	63	21
Unauthorized Camping	8	15	18																	41	14
Vandalism	9	14	17																	40	13
Welfare Checks	60	79	66																	205	68
Totals	118	165	164	0	0	0	0	0	0	0	0	0	0	0	0	0	0	0	0	447	149

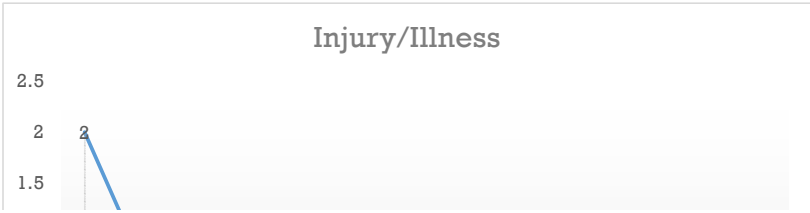
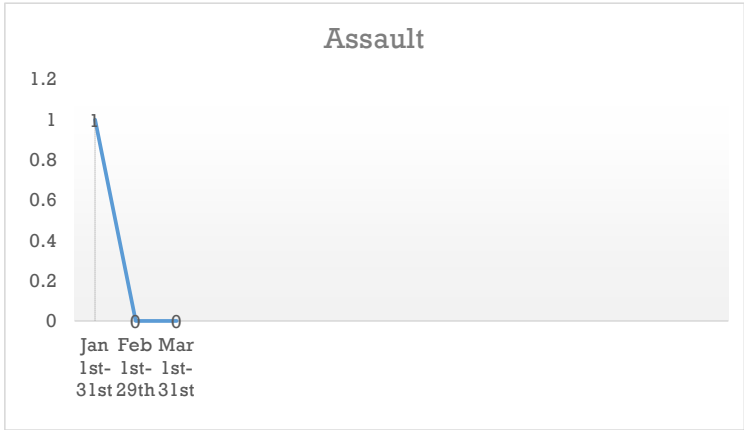
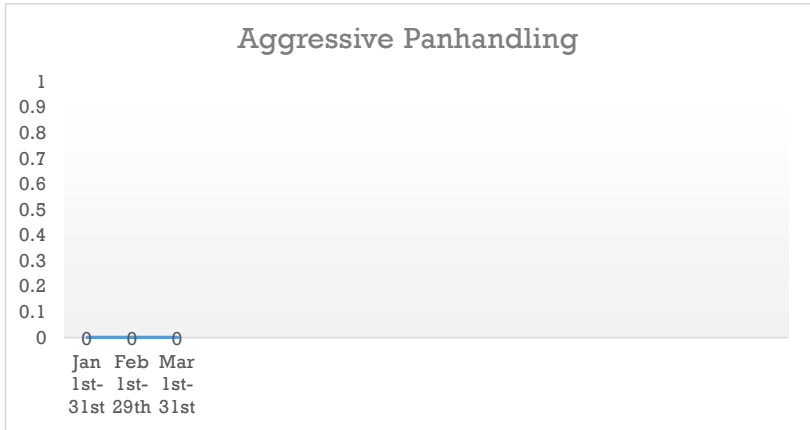

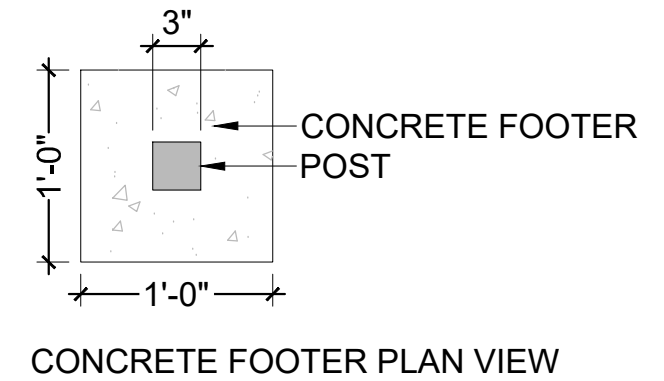
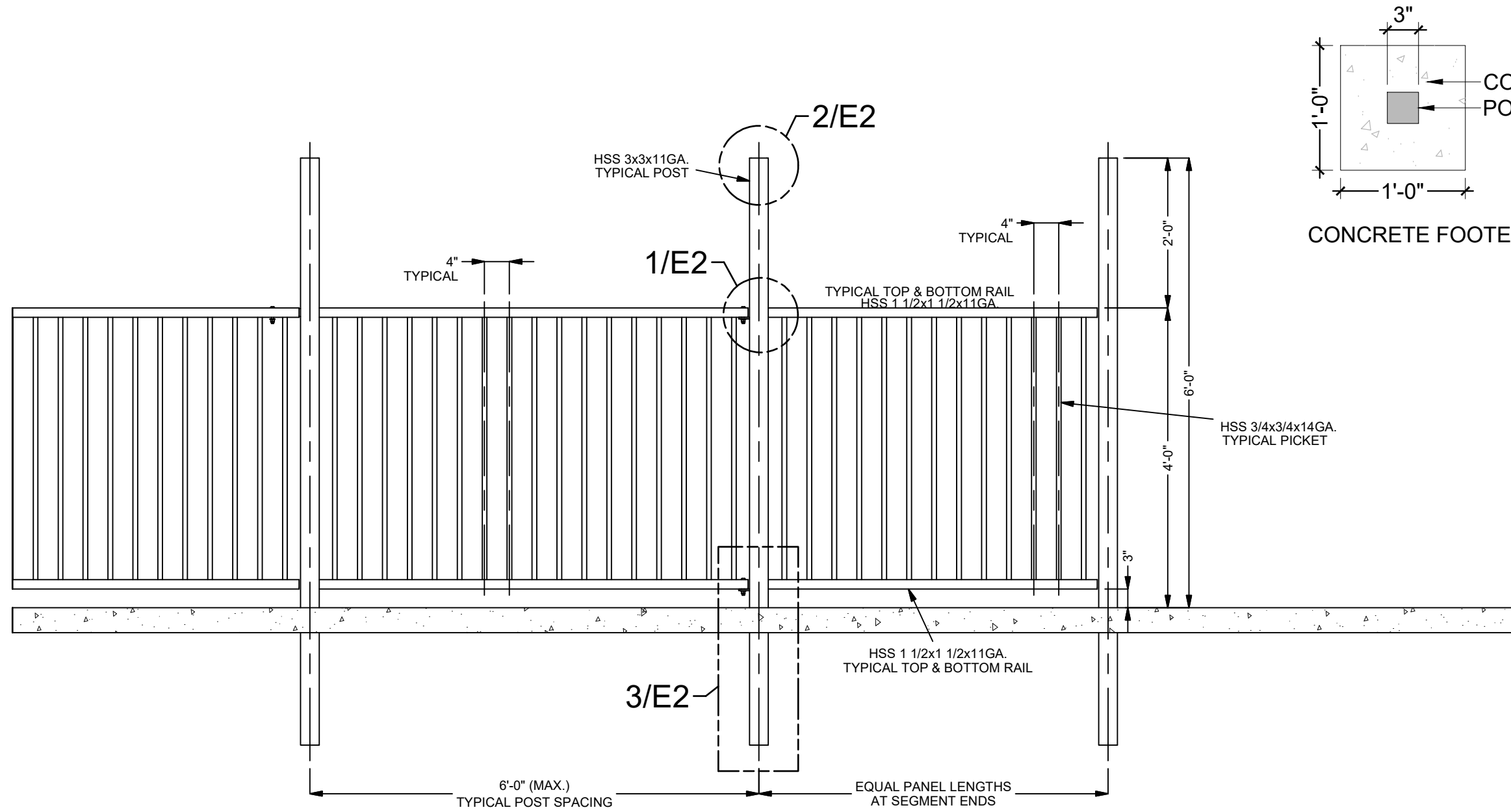

TYPICAL ELEVATION

17TH STREET GARDEN RENOVATIONS
GUARDRAIL DESIGN - 4' FENCE

STAMP: (IF REQ'D)	5		
	4		
	3		
	2		
	1		
	0		
	NO.	DATE	REVISION
			BY
<small>PROPRIETARY DOCUMENT</small> <small>This document contains proprietary information which is the exclusive property of K & K CUSTOM FABRICATION & WELDING. It is loaned for the express purpose described in the transmittal. Neither the document nor the information therein is to be copied, used or transferred without express written permission from K & K CUSTOM FABRICATION & WELDING INC. ©2020 K & K CUSTOM FABRICATION & WELDING INC.</small>			
WO#	24-100		
	DRAWN BY: SWM		CHECKER:
DESCRIPTION: 4FT FENCE		SHEET: E1	
STRUCTURE: GUARDRAIL		FINISH: P.C.	
LOCATION: DENVER, COLORADO		CUSTOMER: DESIGNSCAPES COLORADO	
NOTE:			

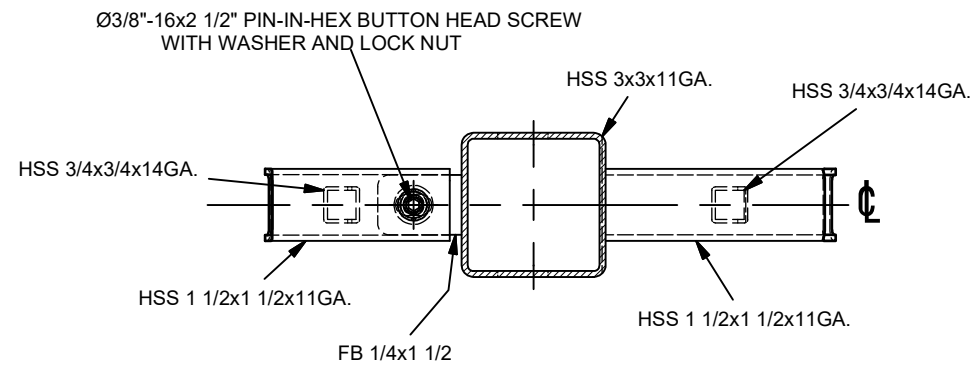

SECTION A-A

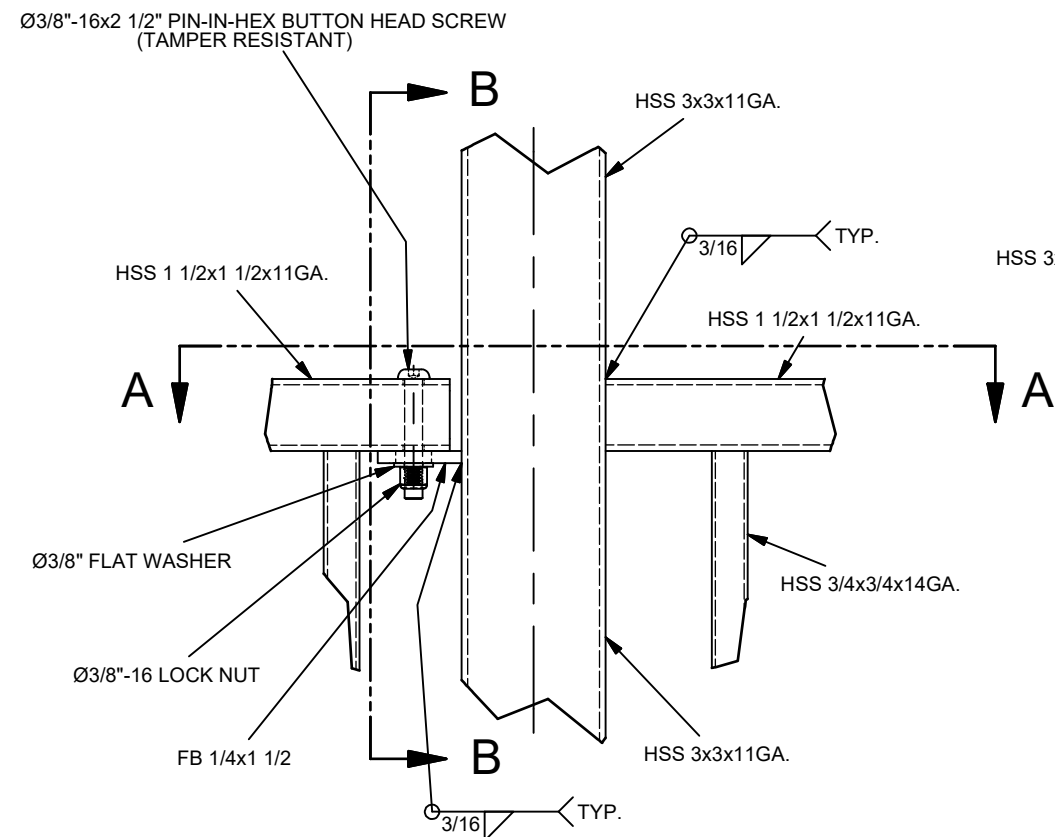

DETAIL 1/E2

TYPICAL PANEL TO POST CONNECTION DETAIL
4 FT. FENCE IS SHOWN, 30" FENCE IS SIMILAR

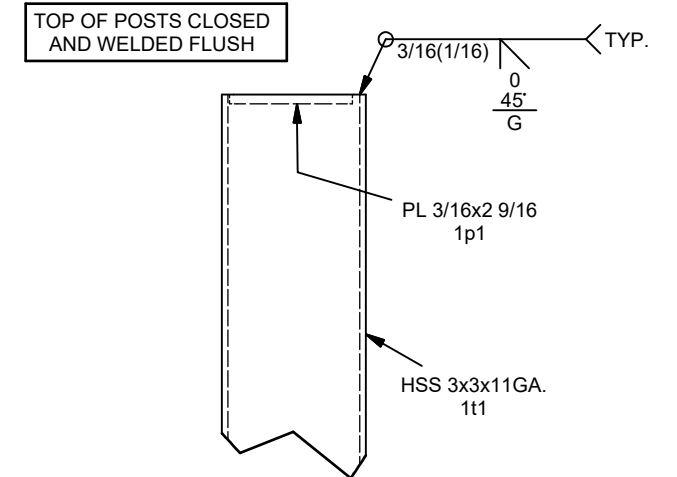
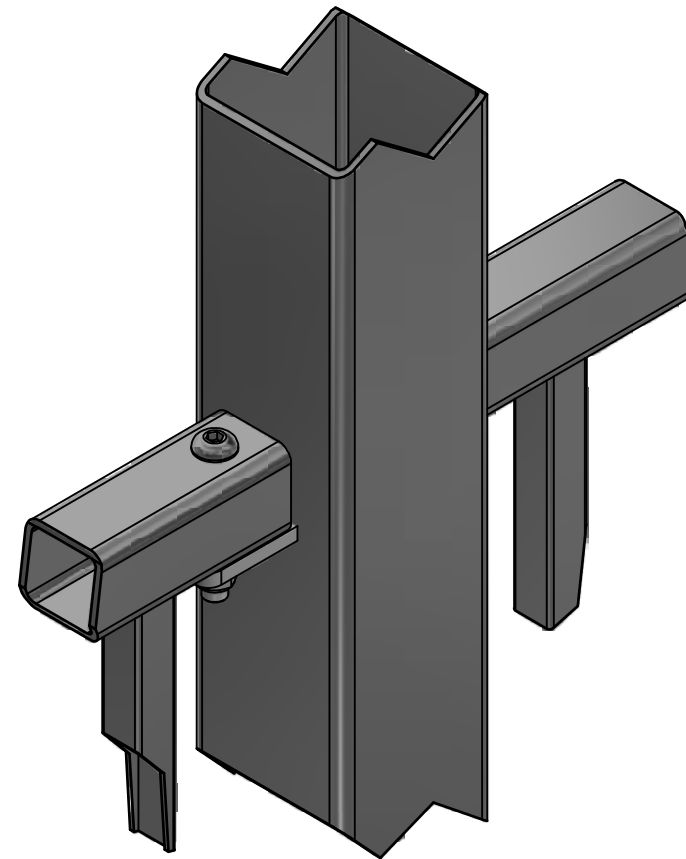

DETAIL 2/E2

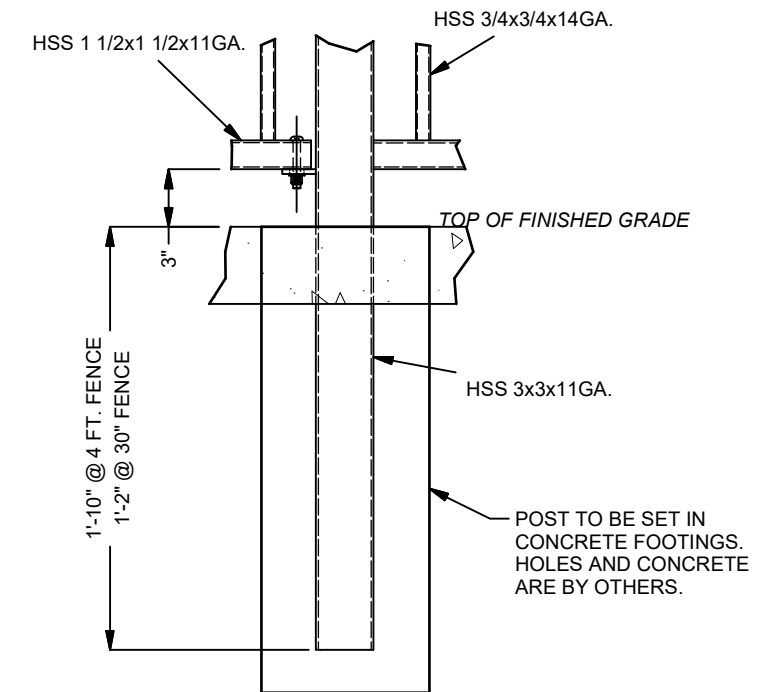

DETAIL 3/E2

TYPICAL POST EMBEDMENT DETAIL
4 FT. FENCE IS SHOWN, 30" FENCE IS SIMILAR

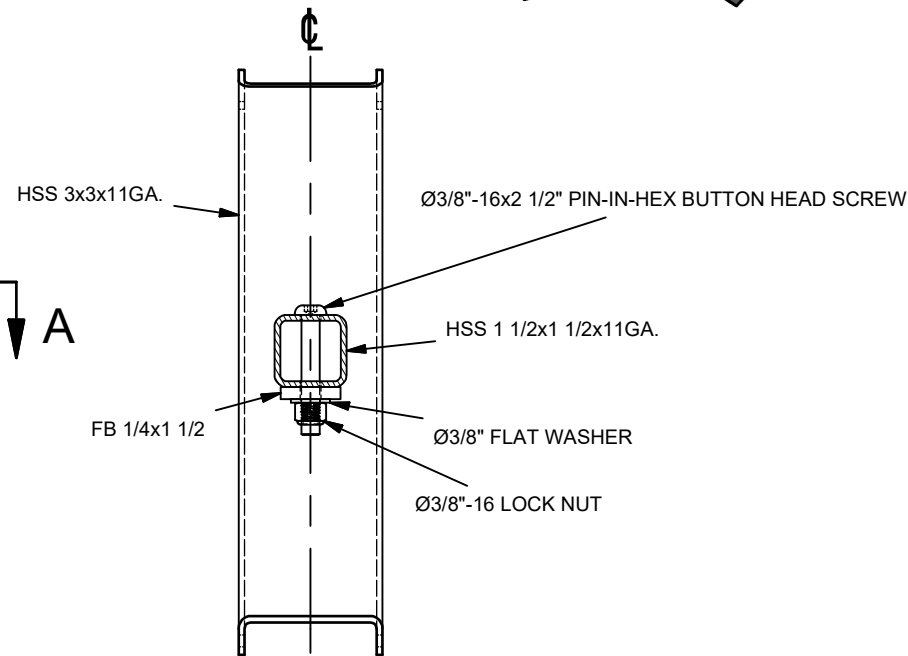

SECTION B-B

STAMP: (IF REQ'D)	5		
	4		
	3		
	2		
	1		
	NO.	DATE	REVISION
			BY
<small>PROPRIETARY DOCUMENT</small> <small>This document contains proprietary information which is the exclusive property of K & K CUSTOM FABRICATION & WELDING. It is loaned for the express purpose described in the transmittal. Neither the document nor the information therein is to be copied, used or transferred without express written permission from K & K CUSTOM FABRICATION & WELDING INC. ©2020 K & K CUSTOM FABRICATION & WELDING INC.</small>			
	STRUCTURE: GUARDRAIL FINISH: P.C. LOCATION: DENVER, COLORADO CUSTOMER: DESIGNSCAPES COLORADO		
	NOTE:		
WO#	24-100		
	DRAWN BY: SWM DESCRIPTION: FENCING DETAILS		CHECKER: SHEET: E2

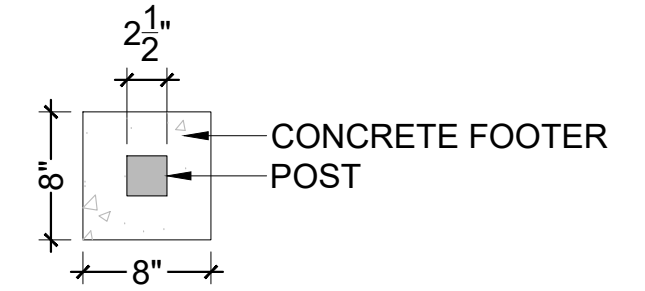

CONCRETE FOOTER PLAN VIEW

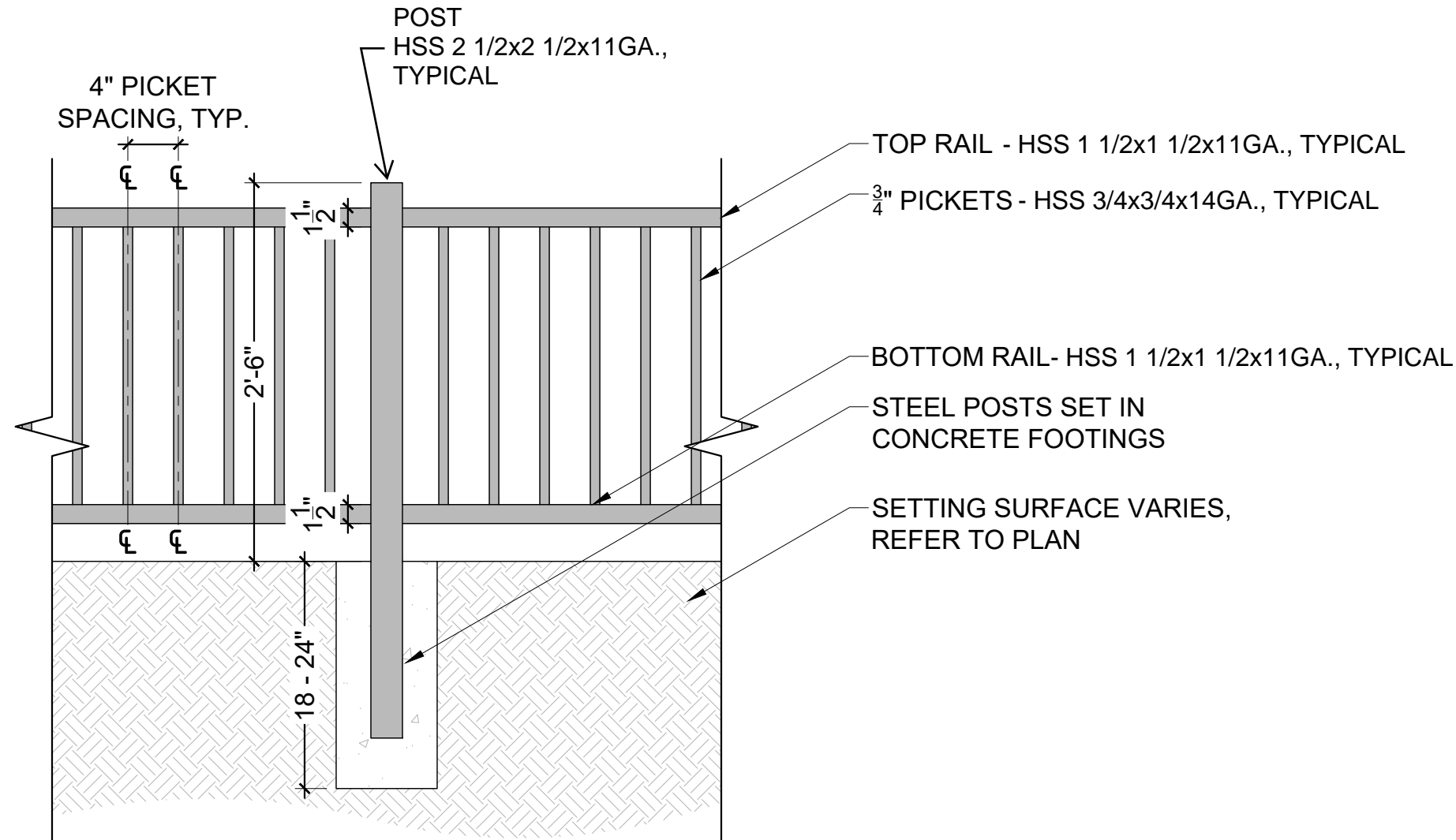

**17TH STREET GARDEN RENOVATIONS
GUARDRAIL DESIGN - 30" FENCE**

STAMP: (IF REQ'D)	5		
	4		
	3		
	2		
	1		
	0		
	NO.	DATE	REVISION
			BY
<small>PROPRIETARY DOCUMENT This document contains proprietary information which is the exclusive property of K & K CUSTOM FABRICATION & WELDING. It is loaned for the express purpose described in the transmittal. Neither the document nor the information therein is to be copied, used or transferred without express written permission from K & K CUSTOM FABRICATION & WELDING INC. ©2020 K & K CUSTOM FABRICATION & WELDING INC.</small>			
K&K CUSTOM FABRICATION & WELDING INC.	STRUCTURE: GUARDRAIL		
	FINISH: P.C.		
LOCATION: DENVER, COLORADO			
CUSTOMER: DESIGNSCAPES COLORADO			
NOTE:			
WO#	24-100		
	DRAWN BY: SWM		CHECKER:
DESCRIPTION: 30INCH FENCE		SHEET: E3	

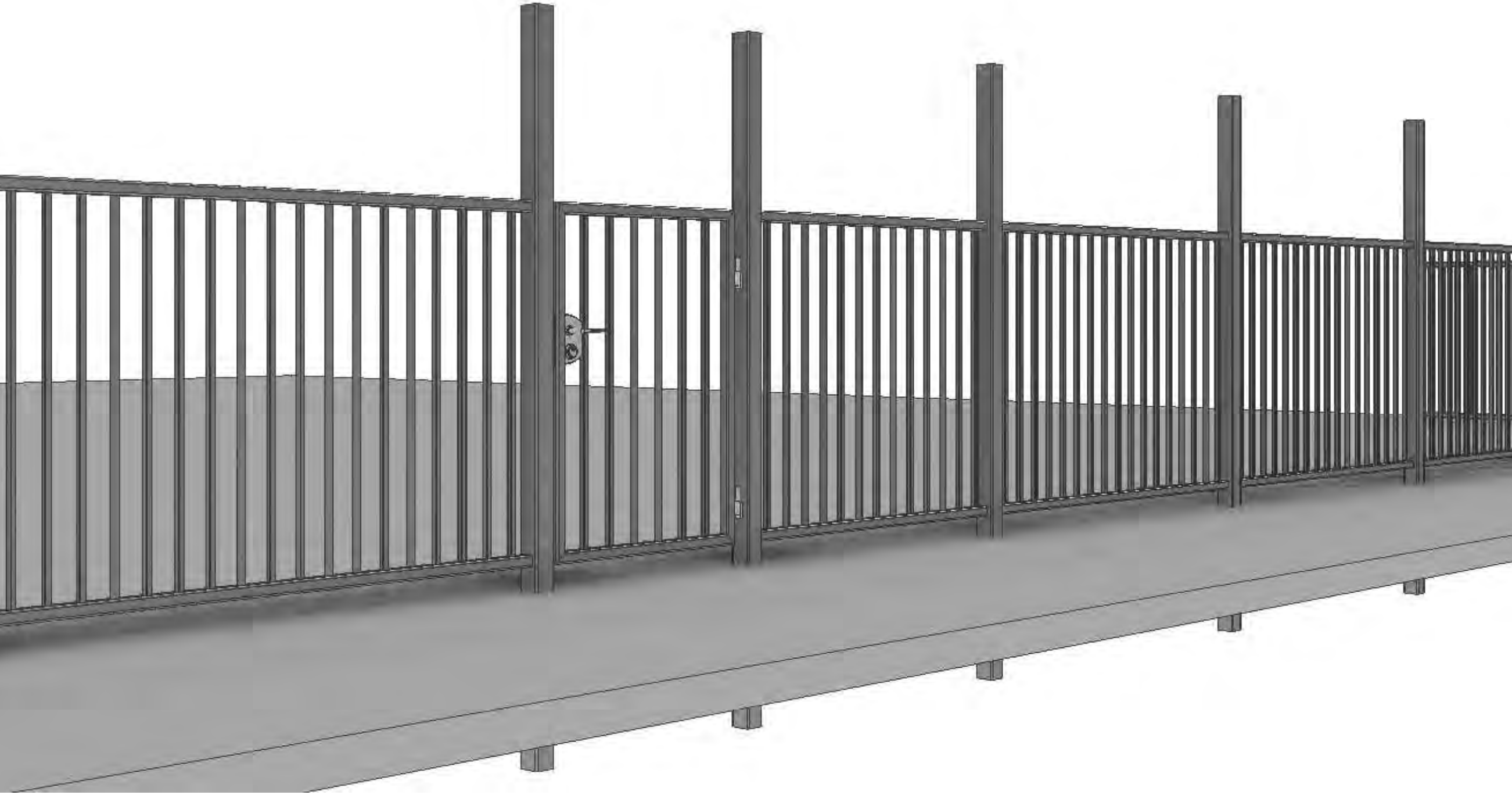



15440 East Fremont - Centennial, Colorado, 80112 - 303.721.9003 - 303-531-7670 fax

To:	Central Platte Valley Coordination Metropolitan District	Contact:	Todd Wenskoski
Address:	8390 E. Crescent Parkway, Suite 300 Greenwood Village, CO 80111	Phone:	303-779-5710
Project Name:	17th Street Garden Renovation - VE - 12/13/2023	Bid Number:	
Project Location:	1701 Wewatta St, Denver, CO	Bid Date:	12/13/2023

Line #	Item #	Item Description	Estimated Quantity	Unit	Unit Price	Total Price
--------	--------	------------------	--------------------	------	------------	-------------

- 1 Pricing accounts for use of 2" x 10" Rough Cedar and additional labor and hardware associated with new lumber size.

Total Additional Pricing: \$3,300.00

Payment Terms:

Payment due within 30 days of date of invoice.

<p>ACCEPTED: The above prices, specifications and conditions are satisfactory and are hereby accepted.</p> <p>Buyer: _____</p> <p>Signature: _____</p> <p>Date of Acceptance: _____</p>	<p>CONFIRMED: Colorado DesignsCAPES, Inc.</p> <p>Authorized Signature: _____</p> <p>Estimator: Sean McNulty 303.721.9003 smcnulty@designscapes.org</p>
---	--



Central Platte Valley Coordination Metropolitan District Manager's and Property Update

May 7, 2024

Bridge Elevators: There were three (3) service calls to TKE for the Millennium Bridge elevators and three (3) for the Union Gateway Bridge in March.

Bridge Camera Monitoring System (Stealth Monitoring): There were 50 incidents reported by Stealth Monitoring in the month of April in and around the elevators, which is lower than March 2024.

EWUM Team Summary of Tasks- Please see attached reports and work orders from our Maintenance Team.

- Daily walks of the Central Platte Valley Metropolitan District Areas.
- Daily cleaning of the elevator including vacuuming the tracks and removal of graffiti
- Elevator inspections two times per day.
- Weekly exterior lighting check on both bridges completed by East West maintenance.
- Security Coordination including payroll and scheduling adjustments as needed.
- Programming of the Millennium Bridge lights according to 2024 schedule.

General Items

- Installed artificial turf on Wewatta Street in front of The Coloradan.
- Removed damaged tree guards.
- Completed tree ring audit and will order replacements rings as needed.
- Met with landscaper to review and plan for 2024 plantings in medians on Wewatta Street.
- Met with 17th Street Gardens vendors for DUG project.

Plaza Fountain

- Activated the fountain for Spring and Summer

Eponic Reporting and DPD Incidents

17 incidents were reported by Eponic. The most reported issues were:

- Vandalism/Graffiti.

There was 1 incident reported by DPD.

- Responded first on scene to auto theft in-progress located in the parking garage at 1850 Chestnut. Located both suspects activity attempting to steal a white motorcycle, one wearing a helmet, and both wearing face masks and gloves.

Respectfully submitted by Brandon Fries, CMCA, AMS

All Ticket Types aggregated by Building

Customer: EAST WEST URBAN MANAGEMENT - Millennium Bridge

Timerange : April 1, 2024 12:00 AM - May 1, 2024 11:59 PM

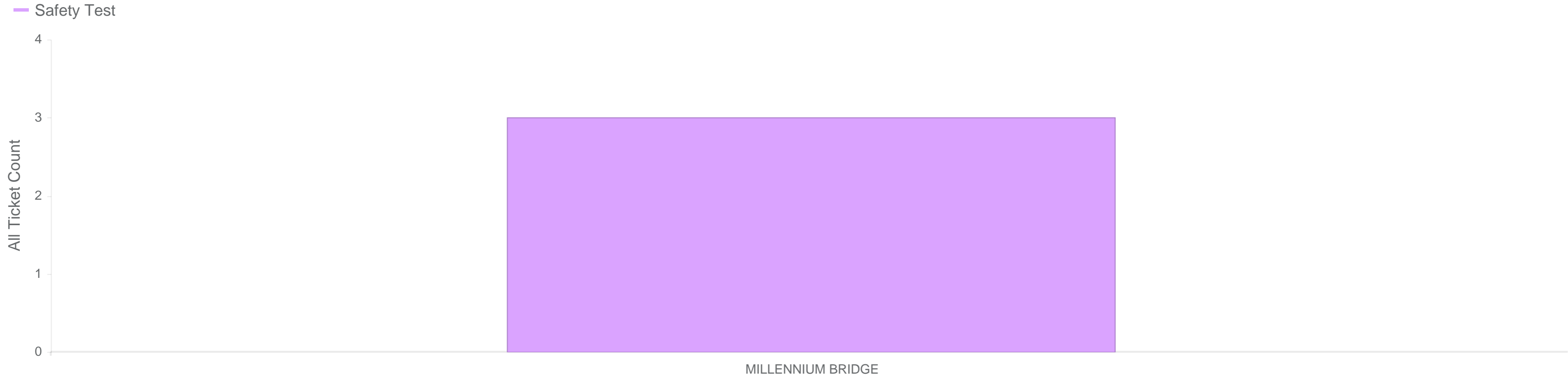

All Ticket Types aggregated by Building

Customer: EAST WEST URBAN MANAGEMENT - Union Gateway Bridge

Timerange : April 1, 2024 12:00 AM - April 30, 2024 11:59 PM

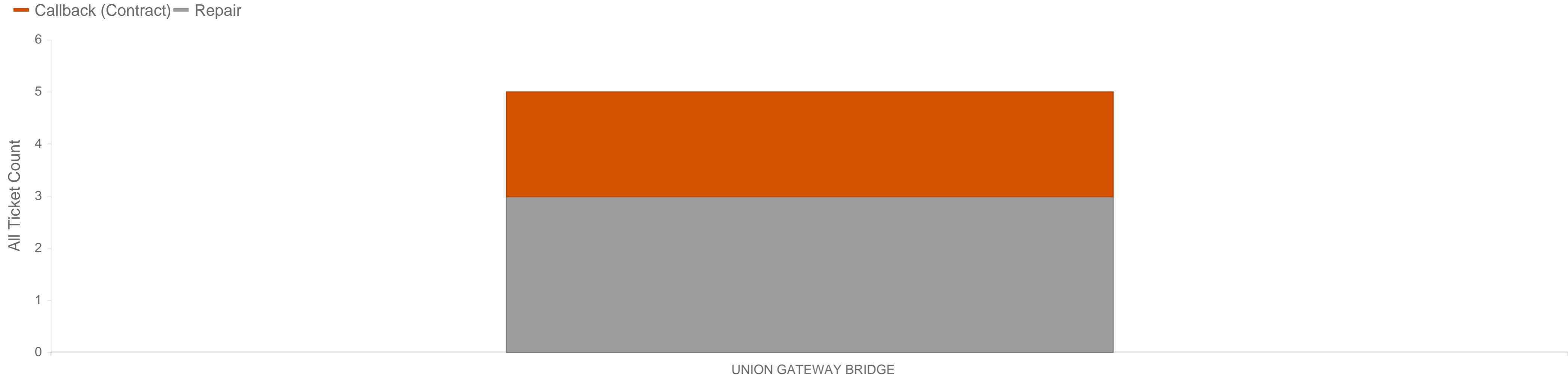

Incident ID	Customer Email	Escalation Reason	Site Identifier	Incident Datetime
497035	An individual was observed loitering on NVR-1, camera 1 at approximately 02:08. The audible alarms were activated. The security officer was contacted and made aware of the activity. The security officer was observed making contact with the individual and appeared to direct them to leave the area.	Loitering/Trespassing	COMillenniumGate	4/1/2024 12:57:00 AM
497068	Two individuals were observed loitering on NVR-1, camera 11 at approximately 03:24. The security officer was contacted and made aware of the activity. The individuals appeared to leave the area with no further incident observed. The security officer was not observed on camera.	Loitering/Trespassing	COMillenniumGate	4/1/2024 2:51:00 AM
497933	An individual was observed loitering on NVR-1, camera 11 at approximately 00:41. The audible alarms were activated. The security officer was contacted and made aware of the activity. The security officer was observed making contact with the individual and direct them to leave the area. 	Loitering/Trespassing	COMillenniumGate	4/3/2024 12:27:00 AM
498471	Multiple individuals were observed loitering on NVR-1, camera 9 at approximately 05:30. The audible alarms were activated. A voicemail was left with the security officer notifying them of the activity. The individuals appeared to leave the area with no further incident observed. The security officer was not observed on camera. 	Loitering/Trespassing	COMillenniumGate	4/4/2024 3:11:00 AM
498480	An individual was observed loitering and appeared to be taking unknown substances on NVR-1, camera 11, at approximately 05:55. The audible alarms were activated. A voicemail was left with the security officer to notify them of the activity. The individual appeared to leave the area without further incident. The security officers were not observed on camera.	Loitering/Trespassing	COMillenniumGate	4/4/2024 5:48:00 AM
498489	Multiple individuals were observed loitering on NVR-1, camera 24 at approximately 07:18. The audible alarms were activated. The individuals appeared to leave the area without further incident observed. 	Loitering/Trespassing	COMillenniumGate	4/4/2024 6:38:00 AM
498789	An individual was observed creating a mess on NVR-1, camera 24, at approximately 00:09. The audible alarms were activated. The individual appeared to leave the area after the audible alarms were activated.	Abnormal People Behavior	COMillenniumGate	4/5/2024 12:00:00 AM

498817	An individual was observed starting a fire on NVR-1, camera 6 at approximately 00:51. The audible alarms were activated. The security officer was contacted and made aware of the activity. The security officer was observed making contact with the individual and appeared to escort them from the property.	Loitering/Trespassing	COMillenniumGate	4/5/2024 12:18:00 AM
499792	An individual was observed loitering on NVR-1, camera 16 at approximately 01:16. The audible alarms were activated. The security officer was contacted and made aware of the activity. The security officer was observed making contact with the individual and appeared to direct them to leave the area.	Loitering/Trespassing	COMillenniumGate	4/7/2024 12:37:00 AM
499833	An individual was observed loitering on NVR-1, camera 11 at approximately 03:30. The security officer was contacted and made aware of the activity. The individual appeared to leave the area with no further incident. The security officer was not observed arriving.	Loitering/Trespassing	COMillenniumGate	4/7/2024 2:00:00 AM
500168	Two individuals were observed engaging in a lewd activity on NVR-1, camera 22 at approximately 20:54. The audible alarms were activated. The security officer was contacted and made aware of the activity. The individuals appeared to leave the area after the audible alarms were activated. The security officer was not observed arriving. 	Misc/Other	COMillenniumGate	4/7/2024 8:51:00 PM
500174	An individual who appeared to be using an unknown substance was observed on NVR-1, camera(s) 11 at approximately 21:10. The audible alarms were activated. The security officer was contacted and made aware of the activity. The security officer was observed making contact with the individual and appeared to direct them to leave the area.	Alcohol/Drug Activity	COMillenniumGate	4/7/2024 9:05:00 PM
500424	Multiple individuals were observed loitering on NVR-1, camera13 at approximately 08:05. One of the individuals was observed vandalising a post. The audible alarms were activated. The individuals appeared to leave the area without further incident observed.	Vandalism/Property Damage	COMillenniumGate	4/8/2024 8:03:00 AM
500857	We observed graffiti on NVR-1, camera 22 at approximately 07:18. Upon review, an individual was observed vandalizing the elevator door. 	Vandalism/Property Damage	COMillenniumGate	4/9/2024 7:17:00 AM
501007	Multiple individuals were observed gathering on NVR-1, camera 8 at approximately 20:33. The security officer was contacted and made aware of the activity. The individuals appeared to leave the area with no further incident observed. The security officer was not observed on camera.	Misc/Other	COMillenniumGate	4/9/2024 8:11:00 PM

502017	An individual was observed loitering on NVR-1, camera 24, at approximately 02:14. The audible alarms were activated. The security officer was contacted and made aware of the activity. The individual appeared to leave the area after the audible alarms were activated. The security was not observed on camera.	Loitering/Trespassing	COMillenniumGate	4/12/2024 2:04:00 AM
502128	An individual was observed loitering on NVR-1, camera 11 at approximately 03:59. The audible alarms were activated. The security officer was contacted and made aware of the activity. The responding officers were observed making contact with the individual and appeared to escort them off the property.	Loitering/Trespassing	COMillenniumGate	4/12/2024 3:57:00 AM
502268	An individual was observed behaving erratically on NVR-1, camera 8 at approximately 17:46. The audible alarms were activated. Denver Police were dispatched at approximately 17:48, due to the nature of the activity observed. The individual appeared to leave the area, with no further incidents observed. The officers were not observed arriving.	Abnormal People Behavior	COMillenniumGate	4/12/2024 5:21:00 PM
502560	An individual was observed taking an unknown substance on NVR-1, camera 11 at approximately 03:07. The audible alarms were activated. The security officer was contacted and made aware of the activity. The security officers were observed making contact with the individual and appeared to direct them to leave the area.	Loitering/Trespassing	COMillenniumGate	4/13/2024 3:00:00 AM
503095	An individual was observed loitering on NVR-1, camera 23 at approximately 05:05. The audible alarms were activated. An attempt to contact the security officer but there was no answer. The individual appeared to leave the area without further incident.	Loitering/Trespassing	COMillenniumGate	4/14/2024 4:58:00 AM
502838	An individual was observed loitering on NVR-1, camera 6 at approximately 20:08. The audible alarms were activated. The security officer was contacted, and made aware of the activity. The individual appeared to leave the area, with no further incidents observed. The security officer was not observed on camera.	Loitering/Trespassing	COMillenniumGate	4/14/2024 7:42:00 PM
503814	An individual was observed loitering on NVR-1, camera 22 at approximately 21:37. The audible alarms were activated. The security officer was contacted and made aware of the activity. The security officer was observed making contact with the individual and appeared to direct them to leave the area.	Loitering/Trespassing	COMillenniumGate	4/15/2024 9:16:00 PM

503902	An individual was observed loitering on NVR-1, camera 5 at approximately 23:49. The audible alarms were activated. The security officer was contacted and made aware of the activity. The security officer was observed making contact with the individuals and appeared to direct them to leave the area.	Abnormal People Behavior	COMillenniumGate	4/15/2024 11:46:00 PM
503971	An individual was observed loitering on NVR-1, camera 21 at approximately 01:36. The security officer was contacted and made aware of the activity. The individual appeared to remain in the area with no further incident observed. The security officer was not observed on camera.	Loitering/Trespassing	COMillenniumGate	4/16/2024 12:25:00 AM
504325	An individual was observed loitering on NVR-1, camera 13 at approximately 22:45. The audible alarms were activated. The security officer was contacted and made aware of the activity. The individual appeared to leave the area with no further incident observed. The security officer was observed patrolling the area.	Loitering/Trespassing	COMillenniumGate	4/16/2024 10:04:00 PM
504808	An individual was observed loitering on NVR-1, camera 11, at approximately 00:23. The audible alarms were activated. The security officer was contacted and made aware of the activity. The responding officer appeared to make contact with the individual and escort them from the property.	Loitering/Trespassing	COMillenniumGate	4/18/2024 12:21:00 AM
504937	An individual was observed loitering on NVR-1, camera 21, at approximately 07:35. The audible alarms were activated. The security officer was observed making contact with the individual and appeared to direct them to leave the area.	Loitering/Trespassing	COMillenniumGate	4/18/2024 7:35:00 AM
505062	An individual was observed behaving erratically on NVR-1, camera 24 at approximately 18:49. The audible alarms were activated. The security officer was contacted, and made aware of the activity. The individual appeared to leave the area, with no further incidents observed. The security officer was observed patrolling the area.	Loitering/Trespassing	COMillenniumGate	4/18/2024 6:39:00 PM
505327	An individual was observed loitering on NVR-1, camera 25 at approximately 03:07. The audible alarms were activated. The security officer was contacted and made aware of the activity. The security officers were observed making contact with the individual and appeared to direct them to leave the area.	Loitering/Trespassing	COMillenniumGate	4/19/2024 2:49:00 AM

505557	<p>Two individuals were observed tampering with the camera on NVR-1, camera 5 at approximately 20:35. The audible alarms were activated. The security officer was contacted and made aware of the activity. The individuals appeared to leave the area with no further incident observed. The security officer was observed patrolling the area.&nbsp;A service ticket has been opened to address the issue with tampered cameras. Someone from our Customer Success Department will be reaching out to you with additional details.</p>	Vandalism/Property Damage	COMillenniumGate	4/19/2024 8:26:00 PM
505916	<p>An individual was observed loitering on NVR-1, camera 24 at approximately 10:24. The audible alarms were activated. The individual appeared to leave the area without any further incident.&nbsp;</p>	Loitering/Trespassing	COMillenniumGate	4/20/2024 10:18:00 AM
506042	<p>Multiple individuals were observed loitering and using an unknown substance on NVR-1, camera 21 at approximately 19:34. The audible alarms were activated. Denver Police were dispatched at approximately 19:40, due to the nature of the activity observed. The security officer was contacted, and made aware of the activity. The individuals appeared to leave the area, with no further incidents observed. The officers were not observed on camera.&nbsp;</p>	Alcohol/Drug Activity	COMillenniumGate	4/20/2024 7:29:00 PM
506280	<p><p>Two individuals were observed using unknown substances on NVR-1, camera 11, at approximately 4:14. The audible alarms were activated. The security officer was contacted and made aware of the activity. The individuals appeared to leave the area before the security officer could arrive. The responding security officer was observed searching the area.</p><p>&nbsp;</p></p>	Loitering/Trespassing	COMillenniumGate	4/21/2024 1:23:00 AM
506502	<p>Multiple individuals were observed using an unknown substance on NVR-1, camera 16 at approximately 17:24. The audible alarms were activated. The security officer was contacted, and made aware of the activity. The individuals appeared to leave the area, with no further incidents observed. The security officer was not observed on camera.</p>	Alcohol/Drug Activity	COMillenniumGate	4/21/2024 5:22:00 PM
507626	<p>An individual was observed loitering on NVR-1, camera(s) 24 at approximately 00:58. The security officer was contacted and made aware of the activity. The security officers were observed making contact with the individual and appeared to direct them to leave the area.</p>	Loitering/Trespassing	COMillenniumGate	4/24/2024 12:58:00 AM

507671	An individual was observed loitering and appeared to be using an unknown substance on NVR-1, camera 11 at approximately 02:29. The security officer was contacted and made aware of the situation. The individual appeared to leave the area without further incidents. The security officers were observed patrolling the area.	Alcohol/Drug Activity	COMillenniumGate	4/24/2024 2:17:00 AM
508456	Multiple individuals were observed taking an unknown substance on NVR-1, camera 22 at approximately 21:08. The audible alarms were activated. Denver police were dispatched at approximately, 21:12 due to the nature of the activity observed. The responding officer was observed making contact with the individuals and appeared to direct them to leave the area.	Alcohol/Drug Activity	COMillenniumGate	4/25/2024 9:02:00 PM
508503	An individual was observed loitering on NVR-1, camera 21 at approximately 22:30. The audible alarms were activated. The security officer was contacted and made aware of the activity. The security officer was observed making contact with the individual and appeared to direct them to leave the area.	Loitering/Trespassing	COMillenniumGate	4/25/2024 9:49:00 PM
508524	An individual was observed using an unknown substance on NVR-1, camera 11 at approximately 23:05. The audible alarms were activated. The security officer was contacted and made aware of the activity. The individual appeared to leave the area with no further incident observed. The security officer was observed patrolling the area.	Alcohol/Drug Activity	COMillenniumGate	4/25/2024 10:57:00 PM
508953	An individual was observed loitering on NVR-1, camera 16 at approximately 22:57. The audible alarms were activated. The security officer was contacted and made aware of the activity. The individual appeared to leave the area with no further incidents observed. The security officer was not observed on camera.	Loitering/Trespassing	COMillenniumGate	4/26/2024 10:55:00 PM
509264	An individual was observed taking an unknown substance on NVR-1, camera 16 at approximately 10:26. The audible alarms were activated. Denver Police were dispatched at approximately 10:28 due to the nature of the activity observed. The individual appeared to leave the area without further incidents. Responding police were not observed arriving.	Abnormal People Behavior	COMillenniumGate	4/27/2024 10:14:00 AM

509337	<p>An individual who appeared to be needing medical assistance observed on NVR-1, camera 11 at approximately 15:49. The audible alarms were activated. Denver Police were dispatched at approximately 15:51 due to the nature of the activity observed.</p> <p>The individual appeared to leave the area with no further incidents observed.</p> <p>Responding officers were observed arriving.</p>	Misc/Other	COMillenniumGate	4/27/2024 3:16:00 PM
509591	<p>Two individuals were observed taking an unknown substance on NVR-1, camera 6 at approximately 20:13. The audible alarms were activated. The individuals appeared to leave the area after the audible alarms were activated with no further incident.</p>	Alcohol/Drug Activity	COMillenniumGate	4/27/2024 8:00:00 PM
509286	<p>An individual was observed loitering on NVR-1, camera 11 at approximately 12:23.</p> <p>The individual appeared to remain in the area without further incident.</p>	Loitering/Trespassing	COMillenniumGate	4/28/2024 11:54:00 AM
509329	<p>Multiple individuals were observed using an unknown substance on NVR-1, camera 11 at approximately 13:57. An attempt was made to contact Denver Police but no answer. The individuals appeared to leave the area with no further incident observed.&nbsp;</p>	Alcohol/Drug Activity	COMillenniumGate	4/28/2024 1:49:00 PM
509918	<p>An individual was observed loitering on NVR-1, camera 25 at approximately 15:48.</p> <p>The audible alarms were activated. The individual appeared to leave the area with no further incidents observed.</p>	Loitering/Trespassing	COMillenniumGate	4/28/2024 2:49:00 PM
510146	<p>Multiple individuals were observed loitering on NVR-1, camera 24 at approximately 23:42. The audible alarms were activated. The security officer was contacted and made aware of the activity. The individuals appeared to leave the area with no further incident observed.&nbsp;</p> <p>The security officer was not observed on camera.</p>	Loitering/Trespassing	COMillenniumGate	4/28/2024 11:30:00 PM
510434	<p>An individual was observed loitering on NVR-1, camera 17 at approximately 18:19.</p> <p>The audible alarms were activated. The security officer was contacted and made aware of the activity. The responding security officers were observed making contact with the individual and directed them to leave the area.</p>	Loitering/Trespassing	COMillenniumGate	4/29/2024 6:19:00 PM

510727	An individual was observed accessing the property and loitering on NVR-1, camera 11, at approximately 02:12. The audible alarms were activated. The security officer was contacted and made aware of the activity. The security officers were observed making contact with the individual and appeared to direct them to leave the area.	Loitering/Trespassing	COMillenniumGate	4/30/2024 1:55:00 AM
511113	Multiple individuals were observed loitering on NVR-1, camera 8 at approximately 23:37. The audible alarms were activated. The security officer was contacted and made aware of the activity. The responding officers were observed making contact with the individuals and appeared to direct them to leave the area.	Loitering/Trespassing	COMillenniumGate	4/30/2024 11:31:00 PM

Work Order Listing Report

WO Number	Unit Ref. Number	Service Provider	Status	Fixed Asset Serial #	Entry Date	Scheduled Date	Scheduled Time	Estimated Hours	Work Order Description
136101	CPV-16	MKRU	Completed		4/8/2024	4/7/2024	12:00 AM	0.25	Bridge Walk...Checked bridge elevators to make sure they are operating correctly, checked, & looked for any graffiti, trash, damage, vandalism. □KX□□6L□□zK□°é·ù□
136677	CPV-16	MKRU	Completed		4/29/2024	4/28/2024	12:00 AM	0.25	Bridge Walk...Checked bridge elevators to make sure they are operating correctly, checked, & looked for any graffiti, trash, damage, vandalism.
136272	CPV-16	MKRU	Completed		4/15/2024	4/14/2024	12:00 AM	0.25	Bridge Walk...Checked bridge elevators to make sure they are operating correctly, checked, & looked for any graffiti, trash, damage, vandalism.
136432	CPV-16	JP	Completed		4/20/2024	4/20/2024	12:00 AM	1.00	Bridge walk. Checked elevator cabs for trash and graffiti. Ran both elevators.
136627	CPV-16	EHERBERT	Completed		4/26/2024	4/26/2024	12:00 AM	1.00	# 16 BRIDGE ELEVATORS CABS AT PLAZA # 16 St bridge elevator cabs at the plaza in 16 St bridge cleaning the elevator cabs removing debris sweep and mop the elevators and wipe the elevator cabs now the elevator cabs are clean and ready to use
136646	CPV-16	JP	Completed		4/27/2024	4/6/2024	12:00 AM	1.00	Bridge walk. Checked elevator cabs for trash and graffiti. Tested elevators function.
136647	CPV-16	JP	Completed		4/27/2024	4/13/2024	12:00 AM	1.00	Bridge walk. Checked elevator cabs for trash and graffiti. Tested elevators function.
136716	CPV-16	EHERBERT	Completed		4/29/2024	4/29/2024	12:00 AM	1.00	# 16 BRIDGE ELEVATORS CABS AT PLAZA # 16 St bridge elevator cabs at the plaza in 16 St bridge cleaning the elevator cabs removing debris sweep and mop the elevators and wipe the elevator cabs now the elevator cabs are clean and ready to use
136773	CPV-16	EHERBERT	Completed		4/30/2024	4/30/2024	12:00 AM	1.00	# 16 BRIDGE ELEVATORS CABS AT PLAZA # 16 St bridge elevator cabs at the plaza in 16 St bridge cleaning the elevator cabs removing debris sweep and mop the elevators and wipe the elevator cabs now the elevator cabs are clean and ready to use
136460	CPV-16	MKRU	Completed		4/22/2024	4/21/2024	12:00 AM	0.25	Bridge Walk...Checked bridge elevators to make sure they are operating correctly, checked, & looked for any graffiti, trash, damage, vandalism. West side down

Work Order Listing Report

WO Number	Unit Ref. Number	Service Provider	Status	Fixed Asset Serial #	Entry Date	Scheduled Date	Scheduled Time	Estimated Hours	Work Order Description
136100	CPV-18	MKRU	Completed		4/8/2024	4/7/2024	12:00 AM	0.25	Bridge Walk...Checked bridge elevators to make sure they are operating correctly, Elevators are still down, waiting for parts, checked, & looked for any graffiti, trash, damage, vandalism.
136271	CPV-18	MKRU	Completed		4/15/2024	4/14/2024	12:00 AM	0.25	Bridge Walk...Checked bridge elevators to make sure they are operating correctly, checked, & looked for any graffiti, trash, damage, vandalism.
136431	CPV-18	JP	Completed		4/20/2024	4/20/2024	12:00 AM	1.00	Bridge walk. Checked elevator cabs for trash and graffiti. Ran both elevators.
136676	CPV-18	MKRU	Completed		4/29/2024	4/28/2024	12:00 AM	0.25	Bridge Walk...Checked bridge elevators to make sure they are operating correctly, checked, & looked for any graffiti, trash, damage, vandalism.
136626	CPV-18	EHERBERT	Completed		4/26/2024	4/26/2024	12:00 AM	1.00	Cleaning the elevators cabs in the # 18 bridge elevators cabs sweeping and moping the elevators cabs and wiping the elevators cabs in the #18 bridge elevators cabs
136643	CPV-18	JP	Completed		4/27/2024	4/6/2024	12:00 AM	1.00	Bridge walk. Checked elevator cabs for trash and graffiti. Tested elevators function.
136644	CPV-18	JP	Completed		4/27/2024	4/13/2024	12:00 AM	1.00	Bridge walk. Checked elevator cabs for trash and graffiti. Tested elevators function.
136715	CPV-18	EHERBERT	Completed		4/29/2024	4/29/2024	12:00 AM	1.00	Cleaning the elevators cabs in the # 18 bridge elevators cabs sweeping and moping the elevators cabs and wiping the elevators cabs in the #18 bridge elevators cabs
136772	CPV-18	EHERBERT	Completed		4/30/2024	4/30/2024	12:00 AM	1.00	Cleaning the elevators cabs in the # 18 bridge elevators cabs sweeping and moping the elevators cabs and wiping the elevators cabs in the #18 bridge elevators cabs
136459	CPV-18	MKRU	Completed		4/22/2024	4/21/2024	12:00 AM	0.25	Bridge Walk...Checked bridge elevators to make sure they are operating correctly, checked, & looked for any graffiti, trash, damage, vandalism.
136206	CPV-DIST	MKRU	Completed		4/11/2024	4/11/2024	12:00 AM	2.00	Assisted with the cleanout of the fountain.
136258	CPV-DIST	DL	Completed		4/15/2024	4/1/2024	12:00 AM	1.00	Started draining the plaza fountain.
136389	CPV-DIST	JP	Completed		4/18/2024	4/18/2024	12:00 AM	1.50	Pulled up broken planter fencing on 17th st.
136559	CPV-DIST	DL	Completed		4/25/2024	4/4/2024	12:00 AM	1.00	Started getting the fountain ready for summer. Started draining and cleaning the pit.

REPORT CRITERIA:

Date Range: 4/8/2024 to 4/9/2024

Log Type: Safety : Vandalism/Graffiti, Safety : Mechanical Issues

GeoFence: CPVMD



1 log found

Monday April 8

 Monday April 8 1:06 PM near 1920 Chestnut PI (Zone: ???) 40s	Austin Pettit 26444021
---	----------------------------------

Safety : Vandalism/Graffiti

King Soopers (1950 Chestnut PI)

Graffiti on the windows by the entrance of the garage for king soopers CS: The Pig & the Sprout Chestnut St



REPORT CRITERIA:

Date Range: 4/11/2024 to 4/12/2024

Log Type: Safety : Vandalism/Graffiti, Safety : Mechanical Issues

GeoFence: CPVMD



1 log found

Thursday April 11

	<p>Thursday April 11 3:53 PM near 2023-2029 15th St (Zone: ???) 27s</p>	<p>Duc Nguyen 26467106</p>
--	--	--

Safety : Vandalism/Graffiti

I found some graffiti CS: 15th St & Delgany St



REPORT CRITERIA:

Date Range: 4/18/2024 to 4/19/2024

Log Type: Safety : Vandalism/Graffiti, Safety : Mechanical Issues

GeoFence: CPVMD



9 logs found

Thursday April 18

<p>Thursday April 18 4:09 PM near 1515 Delgany St (Zone: ???) 3m 29s</p>	<p>Wolfgang Meeseburg 26510760</p>
---	--

Safety : Mechanical Issues

Both light covers at the north side of Delgany's pedestrian footbridge (west of the 15th/Delgany intersection) have become disconnected. CS: Delgany St & Chestnut Pl



<p>Thursday April 18 4:13 PM near 2023-2029 15th St (Zone: ???) 2m 54s</p>	<p>Wolfgang Meeseburg 26510761</p>
---	--

Safety : Vandalism/Graffiti

New sticker and other graffiti on the 15th St/RTD overpass wall (by the back corner of the 1515 Delgany St Denver Parking Garage). CS: 15th St & Delgany St



Thursday April 18 4:16 PM
near 1515 Delgany St (Zone: ???)
2m

Wolfgang Meeseburg
26510762

Safety : Vandalism/Graffiti

Graffiti on street light pole and electric box on the south side of the 1515 Delgany St Denver Parking Garage. CS: Delgany St & Chestnut Pl



Thursday April 18 4:20 PM
near 1900 16th Street Mall (Zone: ???)
1m 50s

Wolfgang Meeseburg
26510763

Safety : Vandalism/Graffiti

Graffiti on 1900 16th St Plaza's stone bench. CS: 16th St & Wewatta St



Thursday April 18 4:28 PM
near 2000 16th Street Mall (Zone: ???)
2m 4s

Wolfgang Meeseburg
26510765

Safety : Vandalism/Graffiti

Graffiti on Millennium Bridge's pole base just outside the west elevator. CS: 16th St & Chestnut Pl

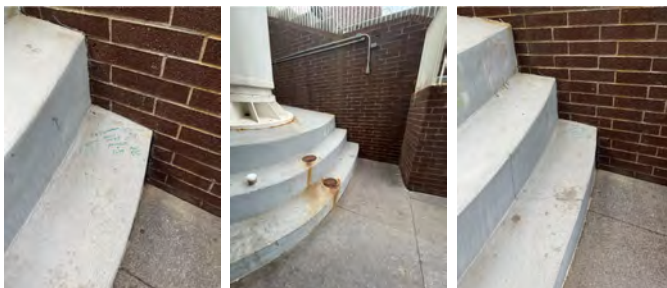

Thursday April 18 4:38 PM
near 2051 16th Street Mall (Zone: Millennium Bridge)
1m 19s

Wolfgang Meeseburg
26510767

Safety : Vandalism/Graffiti

Graffiti on Millennium Bridge's "DANGER: Live Wire" sign on the wooden fence on the right side of the bridge. CS: 17th St & Chestnut Pl



Thursday April 18 4:43 PM
near 2020 17th St (Zone: ???)
1m 12s

Wolfgang Meeseburg
26510768

Safety : Vandalism/Graffiti

Graffiti on electric box outside of Union Station's Chestnut Pavilion. CS: 17th St & Chestnut Pl

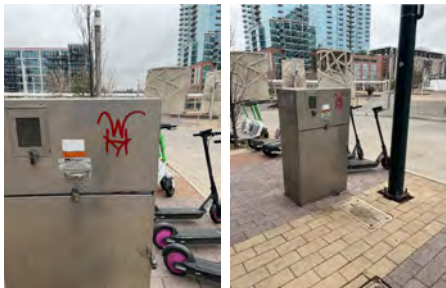

Thursday April 18 5:40 PM
near 1995 Wewatta St (Zone: ???)
1m 44s

Wolfgang Meeseburg
26511347

Safety : Vandalism/Graffiti

Graffiti on the sidewalk running alongside King Soopers north wall (wall closest to 20th St). CS: 20th St & Chestnut Pl





Thursday April 18 11:17 PM
near 1945 17th St (Zone: ???)
1m 32s

43
Wolfgang Meesenburg
26512982

Safety : Mechanical Issues

Exposed wires on street light by the northeast corner of the 17th/Chestnut PI intersection. CS: 17th St & Chestnut PI

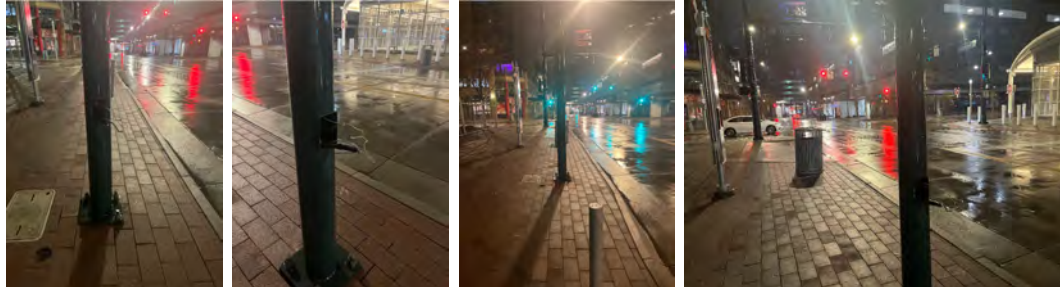

REPORT CRITERIA:

Date Range: 4/19/2024 to 4/22/2024

Log Type: Safety : Vandalism/Graffiti, Safety : Mechanical Issues

GeoFence: CPVMD



1 log found

Saturday April 20

 Saturday April 20 10:08 AM 1850 Chestnut PI (Zone: ???) 1m 41s	Tom McNassor 26521183
---	---------------------------------

Safety : Mechanical Issues

Downed tree branch located on the walkway. Picture taken and data to entered onto Clean & Safe app. CS: 19th St & Chestnut PI

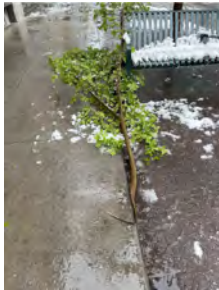

REPORT CRITERIA:

Date Range: 4/25/2024 to 4/26/2024

Log Type: Safety : Vandalism/Graffiti, Safety : Mechanical Issues

GeoFence: CPVMD



2 logs found

Thursday April 25

<p>Thursday April 25 4:10 PM near 1515 Delgany St (Zone: ???) 1m 37s</p>	<p>Wolfgang Meesenburg 26558447</p>
---	---

Safety : Vandalism/Graffiti

Graffiti on one of the support beams of the Delgany pedestrian foot bridge. CS: Delgany St & Chestnut Pl



<p>Thursday April 25 5:38 PM near 1995 Wewatta St (Zone: ???) 1m 35s</p>	<p>Wolfgang Meesenburg 26559000</p>
---	---

Safety : Vandalism/Graffiti

Graffiti on the sidewalk by the King Sooper's 20th St wall. CS: 20th St & Chestnut Pl



REPORT CRITERIA:

Date Range: 4/26/2024 to 4/29/2024

Log Type: Safety : Vandalism/Graffiti, Safety : Mechanical Issues

GeoFence: CPVMD



1 log found

Sunday April 28

	<p>Sunday April 28 12:24 PM near 2059 19th St (Zone: ???) 1m 56s</p>	<p>Austin Pettit 26576295</p>
--	---	---

Safety : Mechanical Issues

King Soopers (1950 Chestnut Pl)

Planter at king soopers off chestnut street got hit by a car or something big enough to move the planter box and broke the water line so it's constantly flowing water out. Notified clean team and king soopers manager of the issue CS: 19th St & Chestnut Pl

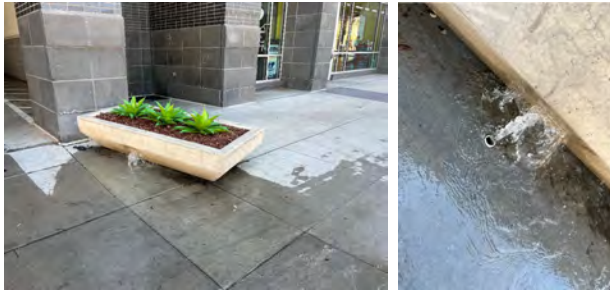

Delivering to Denver 80252
Update location

Tools & Home Improvement

Search Amazon

EN

Hello, sign in
Account & Lists

47
Returns
& Orders



All Medical Care Groceries Best Sellers Amazon Basics Music New Releases Prime

Celebrate National Small Business Month

Tools & Home Improvement Best Sellers Deals & Savings Gift Ideas Power & Hand Tools Lighting & Ceiling Fans Kitchen & Bath Fixtures Smart Home Shop by Room

Sponsored

Home & Kitchen Seasonal Décor Trees



Roll over image to zoom in



Solar Christmas Cone Tree Lights, 6ft 250 LED Christmas Tree Light Show with 8 Modes Timer Remote, Artificial Xmas Tree USB Powered for Indoor Outdoor Yard Porch Patio Holiday Decorations, Warm White

Brand: AMIPEPE

12 ratings

\$59⁹⁹

FREE Returns

Apply now and get a \$10 Amazon Gift Card upon approval of the Amazon Store Card, or see if you pre-qualify with no impact to your credit bureau score.

Color	Warm White
Brand	AMIPEPE
Material	Metal
Theme	Christmas
Item dimensions L x W x H	22.83 x 9.45 x 3.54 inches

About this item

- 2023 New Solar Christmas LED Cone Tree Light: 6 feet 250 LED 15 drops lighted Christmas tree with star topper, The top star diameter is 7.87inch,the lead cable length:16.4ft, perfect size for indoor outdoor decorations. Extra USB powered, allow you to charge Christmas string lights on rainy days or indoors and enjoy bright lights anytime
- Solar Powered & Extra USB: Outdoor Solar Christmas tree lights are powered by sunlight, built-in light sensor, it will charge at daytime and automatically light up at night. High-efficiency solar panel built-in 1200 mAh high capacity rechargeable batteries, work up to 10 to 12 hours after full charge. Extra USB equipped, which allows you to charge the Christmas light in rainy days, and enjoy the bright light anytime and anywhere
- 8 Lighting Modes & Dimmable: Use remote control or press the mode button on solar panel of this Christmas tree star lights to achieve 8 lighting effects, 1.combination, 2.in waves, 3.sequential, 4.slow glow, 5.chasing/flash, 6.slow fade, 7.twinkle/flash, 8.steady on. 1%-100% adjustable brightness to meet your needs
- Timer & Memory Functions: Pre-lit artificial Christmas tree built-in timer function, 6 hrs on and 18 hrs off. With memory function, it can remember the last mode set before power off, very suitable for



Enjoy fast, free delivery, exclusive deals, and award-winning movies & TV shows with Prime
Try Prime and start saving today with fast, free delivery

\$59⁹⁹

FREE Returns

FREE delivery Tuesday, May 7.
Order within 10 hrs 7 mins

Delivering to Denver 80252 - Update location

Only 10 left in stock - order soon.

Quantity: 1

Add to Cart

Buy Now

Ships from Amazon
Sold by Eternal-US
Returns Eligible for Return, Refund or Replacement within 30 days of receipt
Support Product support included

See more

Add a gift receipt for easy returns

Add to List

Sponsored

Delivering to Denver 80252
[Update location](#)

Tools & Home Improvement

Search Amazon

EN Hello, sign in **48** Returns **0**
[Account & Lists](#) & [Orders](#)

All Medical Care Groceries Best Sellers Amazon Basics Music New Releases Prime Customer Service **Celebrate National Small Business Month**

Tools & Home Improvement Best Sellers Deals & Savings Gift Ideas Power & Hand Tools Lighting & Ceiling Fans Kitchen & Bath Fixtures Smart Home Shop by Room

Sponsored

Consider these alternative items



PXBNIUYA 1 Pack Starburst Sphere Lights,200 LED Firework Lights, 8 Modes
3,152
\$9⁹⁸



2 Pack Starburst String Lights Christmas Lights, 225 LED 8 Modes Dimmable with Remote
1,227
\$14⁹⁹



4 Pack Starburst String Lights Christmas Lights, 225 LED 8 Modes Dimmable with Remote
1,227
\$22⁹⁹

Tools & Home Improvement > Lighting & Ceiling Fans > Outdoor Lighting > String Lights



Roll over image to zoom in

PXBNIUYA 3 Pack 600 LED Solar Starburst Sphere Lights Remote Control,LED Firework Lights 8 Modes Dimmable Waterproof Hanging Fairy Light, Copper Wire Lights for Patio Parties Christmas (Warm White)

Visit the [PXBNIUYA Store](#)
3.9 [348 ratings](#)
[Search this page](#)

Color: **3 Pack Solar with Remote**



Size: **3 Pack Solar with Remote**

1 Pack Solar with Remote

2 Pack Solar with Remote

3 Pack Solar with Remote

3 Pack Plug-in with Remote

4 Pack Solar with Remote

4 Pack Plug-in with Remote

Color 3 Pack Solar with Remote

Material Copper

Finish Type Copper

Light Source LED

Type

Power Source Battery Powered

About this item

- **[Upgrade Solar Powered Starburst Lights]**
Solar outdoor firefly lights has been upgraded. There are 2 buttons on the solar panel, namely mode and switch, and 3

No featured offers available
[Learn more](#)

Delivering to Denver 80252 -
[Update location](#)

[See All Buying Options](#)

[Add to List](#)

Sponsored

Sponsored

Tools & Home Improvement > Lighting & Ceiling Fans > Outdoor Lighting > String Lights



4-Pack 160FT 400 LED Solar String Lights for Outside, Solar Lights Outdoor with 8 Lighting Modes, Twinkle Solar Fairy Lights for Tree Christmas Wedding Party Decorations Garden Patio (Warm White)

Visit the LORRYTE Store
4.1 5,238 ratings

Search this page
Amazon's Choice
in Outdoor String Lights by LORRYTE

1K+ bought in past month

Limited time deal
-45% \$22.09 (\$0.14 / Foot)

List Price: \$39.99

Get Fast, Free Shipping with Amazon Prime
FREE Returns

Coupon: Apply 20% coupon
Shop items > | Terms

Eligible for Return, Refund or Replacement within 30 days of receipt

Color: Warm White



Size: 4 Pack 100LED

- 2 Pack 100LED
- 4 Pack 100LED**
- 4 Pack 200LED
- 6 Pack 100LED

Color Warm White
Brand LORRYTE
Indoor/Outdoor Usage Outdoor
Special Feature auto on/off
Light Source Type LED

See more

About this item

- [2024 New Upgraded 4-Pack Super Bright Solar Outdoor Lights] : Super Bright 4-Pack Total 160FT 400 LED with Upgraded Larger



Enjoy fast, free delivery, exclusive deals, and award-winning movies & TV shows with Prime
Try Prime and start saving today with fast, free delivery

Lightning Deal
\$22.09 (\$0.14 / Foot)

14% claimed
Get Fast, Free Shipping with Amazon Prime
FREE Returns

FREE delivery Tuesday, May 7 on orders shipped by Amazon over \$35

Or fastest delivery Monday, May 6. Order within 10 hrs 7 mins

Delivering to Denver 80252 - Update location

Quantity: 1

Add to Cart

Regular Price
\$25.99 (\$0.16 / Foot)
FREE delivery Tuesday, May 7 on orders shipped by Amazon over \$35

Ships from: Amazon
Sold by: zixiaxu

Add to List

Other sellers on Amazon

New (3) from \$25.99 FREE Shipping on orders over \$35.00 shipped by Amazon.

Add other items:

OOTDAY Compact Laundry, 9lbs Front Load Stainless Steel, Clothes Dryers with Exhaust P...
 \$219.79 Add to Cart

Roll over image to zoom in

Sponsored

Home & Kitchen › Seasonal Décor › Seasonal Lighting › Indoor String Lights



Roll over image to zoom in

16 Colors Changing Curtain Lights - 250 LED 9.8 X 8.8 FT Fairy String Lights, 7 Modes Twinkle Lights with Remote, Backdrop Wall Hanging Dripping Lights for Bedroom Backyard Halloween Christmas Decor

Visit the Brighttown Store

4.5 5,239 ratings

Search this page

Amazon's Choice

in Indoor String Lights by Brighttown

500+ bought in past month

-19% \$28⁹⁹ (\$2.96 / Foot)

List Price: ~~\$35.99~~

Get Fast, Free Shipping with Amazon Prime
FREE Returns

Coupon: Apply 15% coupon
Shop items > | Terms

Extra Savings

Save 10% on Patriotic LED Star Stri...
1 Applicable Promotion

Eligible for Return, Refund or Replacement
within 30 days of receipt

Color: **16 colors**



Size: **250 LED**

250 LED 400 LED 540 LED

Color 16 colors

Brand Brighttown

Indoor/Outdoor Outdoor, Indoor
Usage

Special Feature 16+2 Colors; USB+Adapter; 32
Key Remote Control; 7
Lighting Modes

See more

About this item

- Multicolor - 16 wonderful colors and 3 colorful lights in one set, the curtain string lights are wonderful decor for indoor, outdoor, bedroom, window, dorm, party, wedding, birthday, Christmas.



Enjoy fast, free delivery, exclusive deals, and award-winning movies & TV shows with Prime
Try Prime and start saving today with fast, free delivery

Delivery

Pickup

\$28⁹⁹ (\$2.96 / Foot)

Get Fast, Free Shipping with Amazon Prime
FREE Returns

FREE delivery **Tuesday, May 7** on orders shipped by Amazon over \$35. Order within 10 hrs 7 mins

Delivering to Denver 80252 - Update location

In Stock

Quantity: 1

Add to Cart

Buy Now

Ships from Amazon
Sold by Brilliant Light Inc
Returns Eligible for Return, Refund or Replacement within 30 days of receipt
Payment Secure transaction

Add a gift receipt for easy returns

Add to List

Other sellers on Amazon

New (2) from \$28⁹⁹ FREE Shipping on orders over \$35.00 shipped by Amazon.

Add an Accessory:

Amazon Basics Extension Cord, 13 Amps, 125V, 20 Foot, White
\$13.99 [Add to Cart](#)

CREOS

The TUNNEL

Service Offer

Central Platte Valley Metropolitan District
Denver, CO
March 2024



We are specialized in the conception and artistic development of open spaces.

WE PUT FORWARD CONCEPTS THAT ALLOW THE DEMOCRATIZATION OF PUBLIC SPACE.

Creos offers artistically strong proposals, permanent or ephemeral, that respond to the requirements and limitations of the public spaces it promotes.

Specialized in the coordination of stakeholders involved in the creation of open space, our team has the expertise to accompany our clients in all phases of the project.





turnkey service

OUR TURNKEY SERVICES HELP YOU DESIGN UNFORGETTABLE AND ONE-OF-A-KIND PUBLIC SPACES.

Creos handles all details to ensure smooth implementation.

- Production of on-site implementation plans and ongoing follow-up with your team.
- Transportation
- On-site coordination of all setup and dismantle operations.
- Coordination of teams of local crew to assemble and disassemble and on-site training.
- Overall exhibit assistance during activation
- Half-way maintenance during the long-term presentation
- Marketing support during presentation + Signage board on site



The TUNNEL

Lighting the Way

Some of our most imaginative adventures start with a door, a portal, or a gate. Passing through **The TUNNEL** indicates the start of a journey beyond the known world into something transformative.

One thing **The TUNNEL** does best it's light up a site. Its polished exterior reflects the surrounding urban landscape, while the main led pixel bars provide a stunning 100 feet beacon of light. . But **The TUNNEL** offers even more.

You are invited to take control of the experience! **The TUNNEL** utilizes a custom, interactive console that allows you to become the "pilot", guiding other guests through the experience by taking control of the array. Each button controls an aspect of the light programming, including speed, colour, fade and patterns, allowing "pilots" to tailor a unique experience. The giant light structure can also run autonomously for hours on end.

This memorable immersive experience transports you to a place of pure imagination that quickly becomes an inspiring new reality.

Creator
BIG ARTTour Producer
CREOS



BIG ART

Creator

We are built for one purpose – make more public art. We design, build and promote interactive, and immersive, works of wonder so we can inspire the next. From fire-shooting portals to code-talking cubes from another dimension, we live for interactive and immersive art installations.

Advancements in technology have allowed us to realize creative dreams we never thought possible, and in that spirit, we embrace the technology of yesterday, today, and tomorrow to create large-scale, tour-ready, turnkey installations and experiences.

We are passionate about what we do and are committed to delivering inspiring encounters. Whether you choose something from our current catalogue, or connect with us for a custom commission, we pride ourselves on delivering creative, robust, safe, and reliable installations and experiences.

“ A memorable immersive experience should take someone to a place of pure imagination, that quickly becomes a new and inspiring reality. ”

BUDGET

The TUNNEL

100' unit

4 weeks

Artwork		\$21 000,00
Production team fees		\$10 027,50
Ancillary fees		\$2 255,00
Logistic material rental	Provided by local producer	\$0,00
Production material		\$3 086,25
Transportation - Team and Artwork		\$22 387,50
Lodging		\$1 687,50
Per diem fees		\$743,05
Security	Provided by local producer	\$0,00
Local workforce	Provided by local producer	\$0,00
Subtotal		\$61 186,80
Administration	10%	\$6 118,68
Total		\$67 305,48
Total in USD		\$52 100,98

Pricing is in \$CAD

BUDGET

The TUNNEL

100' unit

6 weeks

Artwork		\$30 000,00
Production team fees		\$11 523,75
Ancillary fees		\$2 860,00
Logistic material rental	Provided by local producer	\$0,00
Production material		\$4 087,50
Transportation - Team and Artwork		\$24 356,25
Lodging		\$2 362,50
Per diem fees		\$1 061,50
Security	Provided by local producer	\$0,00
Local workforce	Provided by local producer	\$0,00
Subtotal		\$76 251,50
Administration	10%	\$7 625,15
Total		\$83 876,65
Total in USD		\$64 928,68

Pricing is in \$CAD

BUDGET

The TUNNEL

100' unit

8 weeks

Artwork		\$39 000,00
Production team fees		\$11 655,00
Ancillary fees		\$3 410,00
Logistic material rental	Provided by local producer	\$0,00
Production material		\$5 370,00
Transportation - Team and Artwork		\$24 356,25
Lodging		\$2 362,50
Per diem fees		\$1 061,50
Security	Provided by local producer	\$0,00
Local workforce	Provided by local producer	\$0,00
Subtotal		\$87 215,25
Administration	10%	\$8 721,53
Total		\$95 936,78
	Total in USD	\$74 264,39

Pricing is in \$CAD

Merci Thank you

1-1375, Marie-Victorin St.
Saint-Bruno-de-Montarville
(Québec) J3V 6B7
Canada

514 360-5774 844 992-7367
imagine@creos.io

creos.io

CRE•S

Optik

Service Offer

Central Platte Valley Metropolitan District
Denver, CO
March 2024



We are specialized in the conception and artistic development of open spaces.

WE PUT FORWARD CONCEPTS THAT ALLOW THE DEMOCRATIZATION OF PUBLIC SPACE.

Creos offers artistically strong proposals, permanent or ephemeral, that respond to the requirements and limitations of the public spaces it promotes.

Specialized in the coordination of stakeholders involved in the creation of open space, our team has the expertise to accompany our clients in all phases of the project.



Unrivalled turnkey service

OUR UNRIVALLED TURNKEY SERVICES HELP CLIENTS DESIGN UNFORGETTABLE AND ONE-OF-A-KIND PUBLIC SPACES.

Creos handles all details to ensure smooth implementation.

- Production of on-site implementation plans ongoing follow-up with clients
- Worldwide transportation
- Set-up & teardown
- Coordination of teams of professionals who perform on-site assembly and disassembly On-site training
- Overall exhibit assistance
- Half-way maintenance during long term presentation
- Marketing support

ONE
STOP
SHOP

Optik

A playful vision of a brighter side

Optik is an interactive installation that reflects on our ability to play with our surroundings while giving the opportunity for brand new point of views on our daily environment. It provides a unique platform for users to manipulate at free will how they want to see the world.

The 6 feet (1,8 meters) gyroscope-like forms with, at the center, a dichroic film, offer new ever-changing opportunities that reflect any ray of lights during the day while refracting the inner rings lighting at dusk. As the audience rotates each unit, they create their own endless cascade of colors. The experience is raised to another level as sound joins us on the rhythmical effort, turning each unit into a different musical instrument.

Through movement and reflection of light, each of these colorful units encourages the public to engage with another unit and other people within the space, becoming a communal hub for social connection.

Owner
INIT

Creator
THE URBAN CONGA

Collaborator
SERGE MAHEU

Tour Producer
CREOS

“ The joy I've witnessed outside my window all day and all night is awesomeness... Thanks for bringing it to our fabulous downtown. ”

(@loftyideas504)

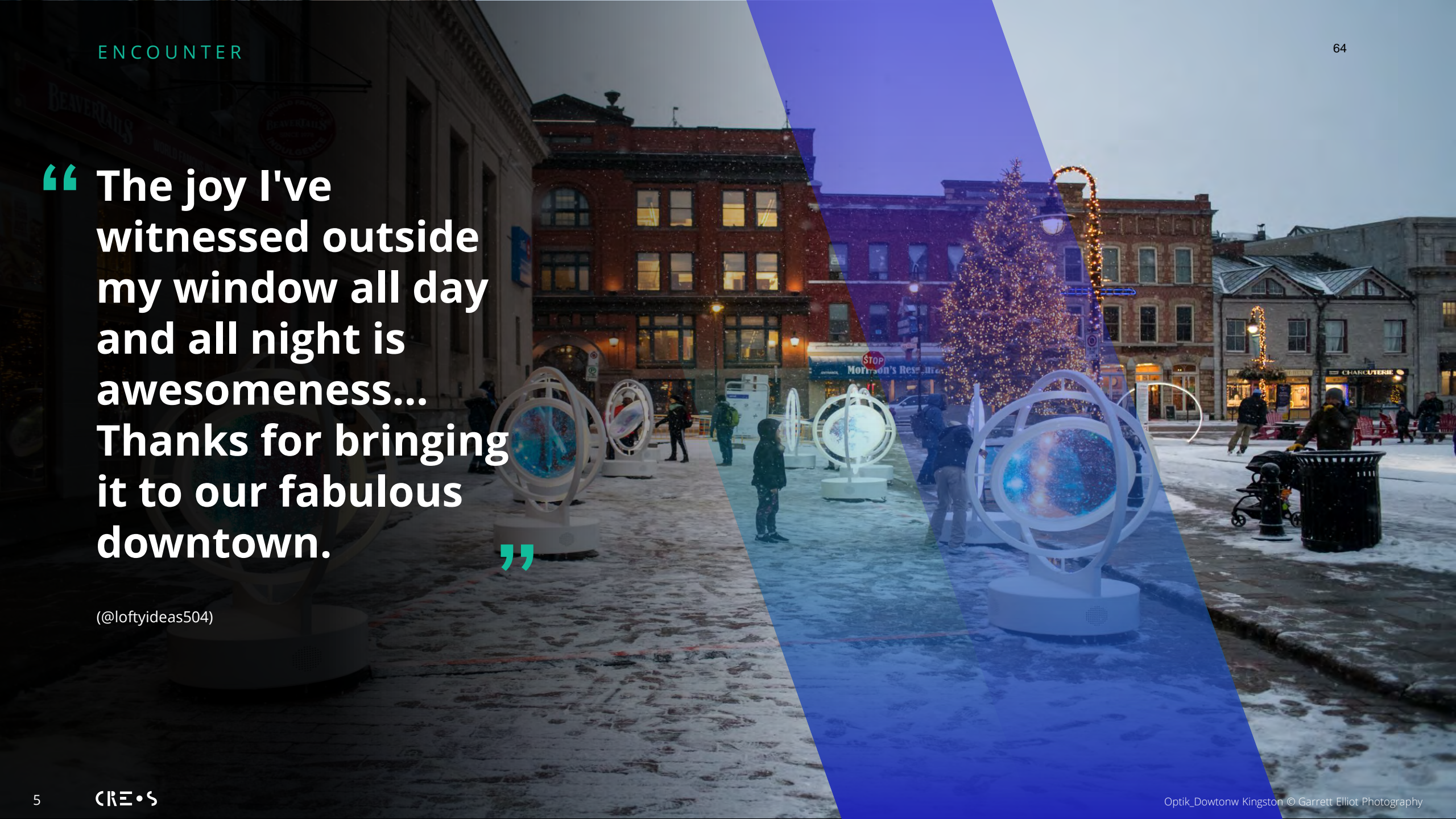



The Urban Conga

Creator

The Urban Conga is an award-winning multidisciplinary design studio focused on sparking community interaction and social activity through open-ended play. Their work explores the idea of creating more playable cities as an ecosystem of inclusive multiscale playable opportunities intertwined with our existing urban fabric. Transforming once overlooked and underutilized situations into equitable, stimulating creative outlets for communal connection.

Architizer A+Awards
2021

WINNER

Film of the Year
Best in Specialization in the
Small Projects Category

NYCxDesign Award
2020

HONOREE

Project "Oscillation" for
Installation of the Year

Interior Design Magazine
2021

AWARDED

Won the Rising Star for
Greater Good Award

BUDGET

Optik

10 units

4 weeks

Artwork		\$23 800,00
Production team fees		\$9 765,00
Ancillary fees		\$2 255,00
Logistic material rental	Provided by local producer	\$0,00
Production material		\$4 154,00
Transportation - Team and Artwork		\$22 387,50
Lodging		\$1 687,50
Per diem fees		\$743,05
Security	Provided by local producer	\$0,00
Local workforce	Provided by local producer	\$0,00
Subtotal		\$64 792,05
Administration	10%	\$6 479,21
Total		\$71 271,26
	Total in USD	\$55 170,88

Pricing is in \$CAD



BUDGET

Optik

10 units

6 weeks

Artwork		\$34 000,00
Production team fees		\$11 130,00
Ancillary fees		\$2 860,00
Logistic material rental	Provided by local producer	\$0,00
Production material		\$5 532,50
Transportation - Team and Artwork		\$24 356,25
Lodging		\$2 362,50
Per diem fees		\$1 061,50
Security	Provided by local producer	\$0,00
Local workforce	Provided by local producer	\$0,00
Subtotal		\$81 302,75
Administration	10%	\$8 130,28
Total		\$89 433,03
Total in USD		\$69 229,85

Pricing is in \$CAD



BUDGET

Optik

10 units

8 weeks

Artwork		\$44 200,00
Production team fees		\$11 130,00
Ancillary fees		\$3 410,00
Logistic material rental	Provided by local producer	\$0,00
Production material		\$6 911,00
Transportation - Team and Artwork		\$24 356,25
Lodging		\$2 362,50
Per diem fees		\$1 061,50
Security	Provided by local producer	\$0,00
Local workforce	Provided by local producer	\$0,00
Subtotal		\$93 431,25
Administration	10%	\$9 343,13
Total		\$102 774,38
	Total in USD	\$79 557,35

Pricing is in \$CAD



Merci Thank you

1-1375, rue Marie-Victorin
Saint-Bruno-de-Montarville
(Québec) J3V 6B7
Canada

514 360-5774 844 992-7367
imagine@creos.io

creos.io



Date: 4/26/2024

Central Platte Valley Metropolitan District Environmental Lighting Concepts

Prepared by: Loren Brinton
lbrinton@displaydevices.com
303-907-8409

SĚNIK REFLEKT RGBW

Scaleable Exterior Floodlight

The SĚNIK Reflekt takes a modern, scalable approach to façade lighting. Featuring individually specifiable fixture heads each with -90° to 90° adjustability, output over 7700 lumens, and modular mounting options (1, 2, or 3 head fixtures). Available with optional LumenRadio wireless DMX and additional accessories to modify performance, the SĚNIK Reflekt offers the ultimate flexibility and efficiency in exterior floodlighting.

- RGB+3000K Standard
- Greater than 23,000 lumen output when using three heads (all channels on)
- -90° to 90° modular and global rotation with locking yokes & 3G vibration rating
- Black finish (gray, white, & custom RAL available special order)
- DMX512 RDM enabled with optional LumenRadio wireless DMX
- cETLus Listed, IP67 (outdoor, wet location)
- Die-cast aluminum housing with marine grade finish
- IK10 impact rating with optional rock guard or louver accessory
- Field interchangeable optical lens accessory available in 25°, 35°, 50°, 65°, 35°x15°, 60°x15°, or wallwash distribution
- Optimized, state-of-the-art heat sink design enables a long life, far exceeding L70>60,000 hours rated life



SĚNIK REFLEKT RGBW QUICK SPECS

VOLTAGE	100-277V AC
WATTAGE	100W 200W 300W
LUMENS	Up to 7756 15512 23268 lumens (all channels on)
CCT OPTIONS	RGB+3000K Special Order CCTs Available
CRI	80+
MOUNTING	Surface mount
DIMMING	DMX512 RDM
OPTICS	12° (native)
MAX POWER LINK	9 (100V) 18 (277V) Single Fixture Heads
MAX SIGNAL LINK	30 Single Fixture Heads
OPERATING TEMP	-40°F to 122°F (-40°C to 50°C)
IP RATING	IP67
IK RATING	IK06 IK10 (when using rock guard or louver accessory)
CERTIFICATIONS	cETLus Listed - Wet Location
RATED LIFE	L70 > 60,000 hours

SĚNIK REFLEKT RGBW EPA (WITH VISOR)

SINGLE HEAD	1.4ft ²
DUAL HEAD	2.9ft ²
TRIPLE HEAD	4.2ft ²

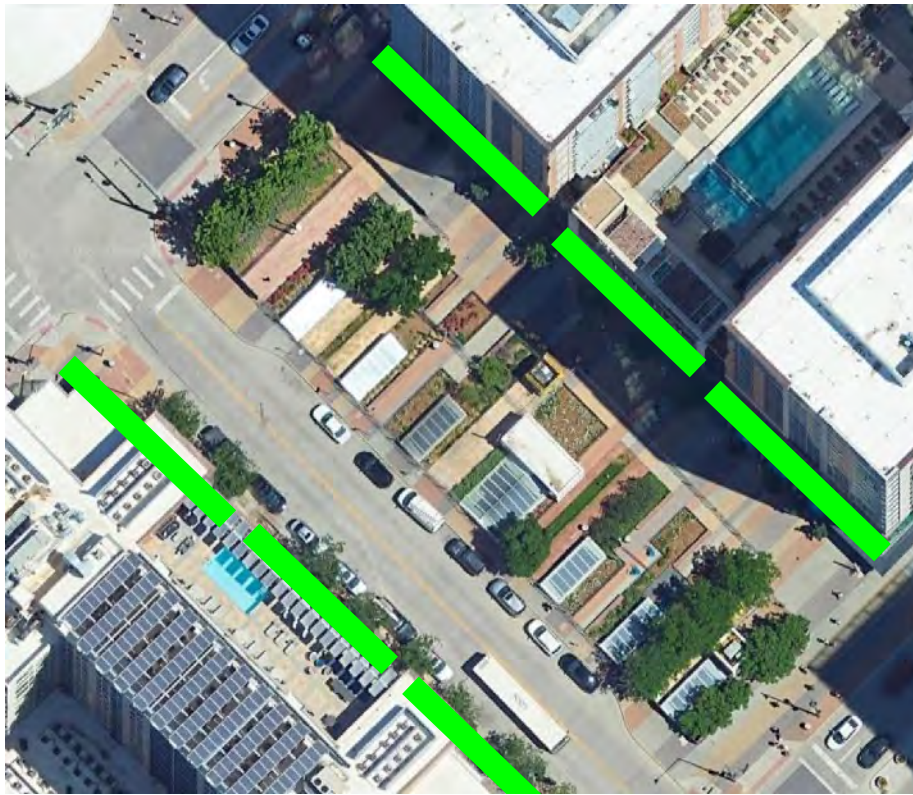

We propose using the Prizm Senik Reflect RGBW exterior floodlights mounted on the facades and awnings of the highlighted locations. These lights will illuminate the sidewalks with a subtle, dynamic motion, enhancing the vibrancy and playfulness of the block.

The fixtures will communicate with the controller using lumen radio, allowing the entire block to be linked together without the need for physical connections between each group of lights. These luminaires are the same system recently installed at Union Station, enabling the lighting schedule to be programmable and synchronized for a cohesive look throughout the block.

PROJECT:
TYPE:
LOCATION:
CATALOG NUMBER:





Link to Video: <https://vimeo.com/939703622>

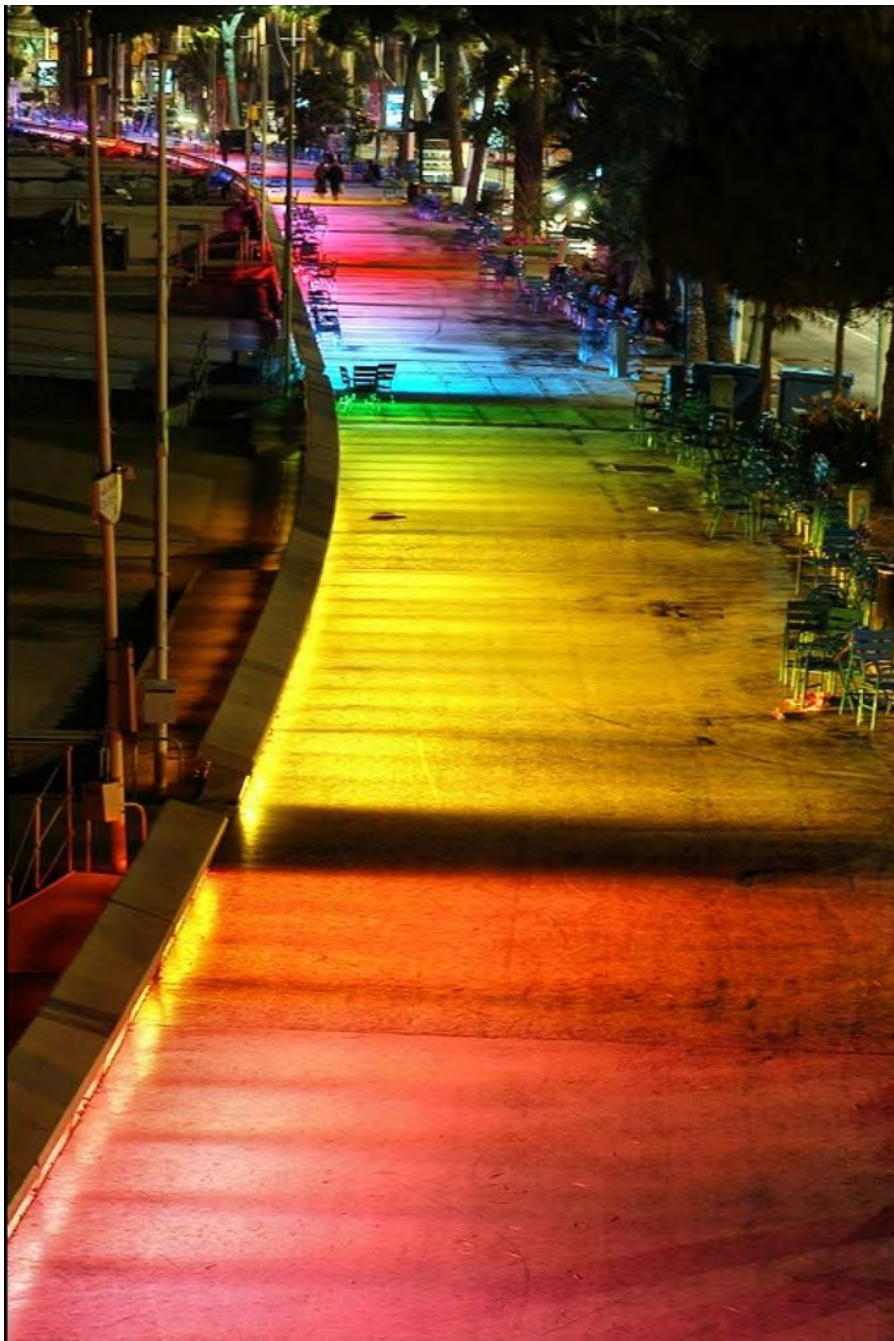

EXPERT MAKES LIGHT OF IT

Benefit from Pharos expertise in dynamic architectural lighting with an all-new, practical, and straightforward control solution centred around a single, reliable set-and-forget controller.

With DMX, DALI and a couple of convenient contact closures and relays all on board, Expert Control provides up to 1024 channels and is just the job for architectural lighting that requires the benefits of dynamic movement and colour in a cost-effective and user-friendly package.

Expert Software helps and guides you through programming the controller. Also available is a companion 5" touchscreen; the elegant Expert Touch, and completing the range are two accessories: Expert Repeat which is a convenient DMX splitter for output distribution, and Expert Switch for PoE networking.

With the reliability you expect from Pharos and our expertise in dynamic lighting in architecture and entertainment: an easy to install, easy to use control solution.



One Controller

All you need in one stand-alone box. Up to 1024 channels of eDMX, two local DMX ports, a DALI port and two pairs of IO onboard with simple networking for programming. All in one compact, DIN rail mount enclosure and optional keyhole hanging, with solid-state hardware for 24/7 operation and reliability.



Network Connectivity

Whatever suits your installation - from a single Ethernet cable direct to a laptop just for programming, or a static, closed network just for your lighting data, to the facility's IT network for greater connectivity, or even to the Internet to connect via Pharos Cloud for fully secure remote access. Expert Switch available to provide an unmanaged network switch with PoE for Expert Control and Touch.



Straightforward installation

Requiring just PoE or conveniently flexible 9-48V DC power range, with install-friendly rising-clamp connectors. Out-of-the-box, the test modes on the rotary dial select the output ports, and the push button allows raising and dimming levels for fixture testing. Test mode and levels can even be maintained indefinitely as working lights before commissioning and programming occur. Rotary dial also provides four programmable override states.



Remote Management

The control you need in your browser - from anywhere. Pharos Controllers can be connected to Pharos Cloud, a secure remote management service from SixEye. This allows direct control of your Controllers from anywhere in the world, letting you check controller status, inputs and outputs, firing events, scheduling events, uploading new projects and much more.



Output

Controllers available in one DMX universe (512 channel) and two DMX universe (1024 channel) capacities. Output over Ethernet to various eDMX lighting protocols, with two self-healing ports for convenient patching to local DMX512. Expert Repeat available for additional local DMX distribution. The DALI port supports control for up to 64 DALI devices, including device discovery and configuration.



Expert Software

Let Expert Software guide you through setting up and creating your lighting design, with helpers and clear, easy-to-follow processes. This desktop app is a brand-new programming platform, designed from scratch to give you just the tools you need, with innovative approaches to scheduling and triggering your lighting, based around an intuitive spaces-based approach which simplifies managing your installation, fixtures and lighting looks. And, it's free for Windows and macOS.



Easy IO Integration

The two inputs / two outputs provide contact closure to interface with controls such as fire alarm systems and key-switch overrides. Receive DALI messages from other controllers such as wall panels or occupancy sensors.

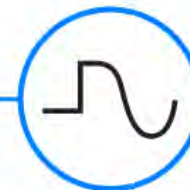

Reliability

Made for permanent installation, with installer-friendly connectors and easy DIN rail mounting. Hardware and firmware are self-sufficient, so no PC needs to be left on site. Compact unit designed for 24/7 operation and reliability.



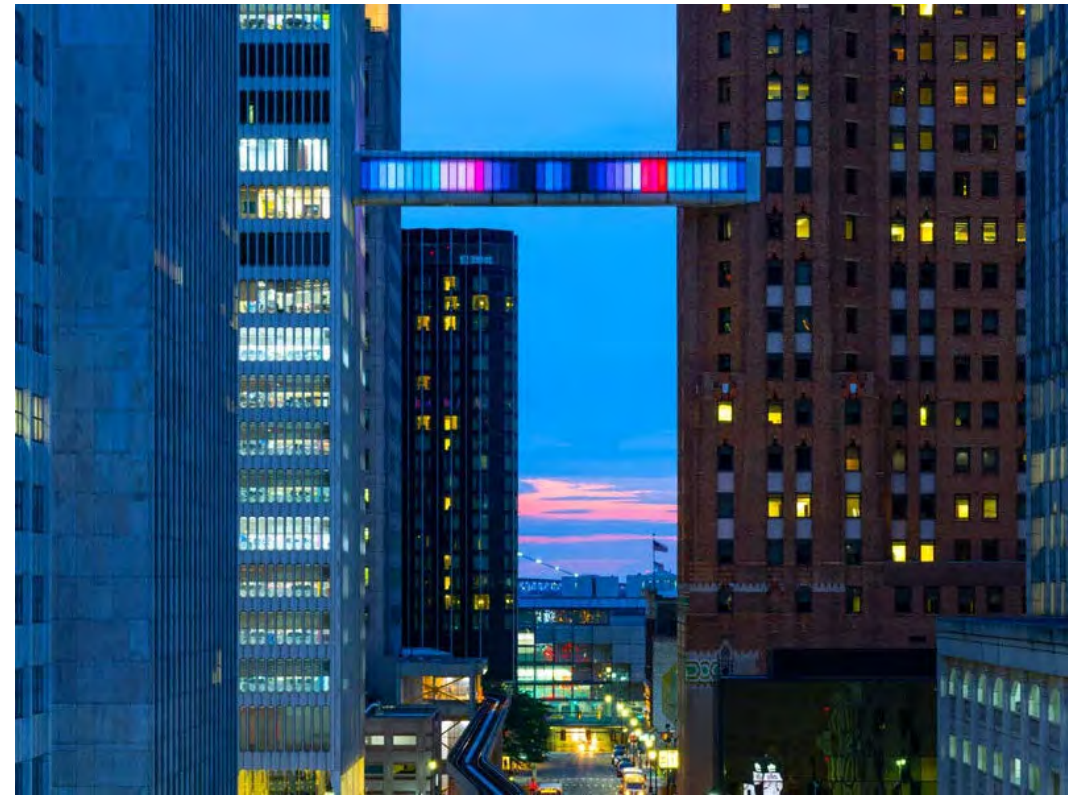
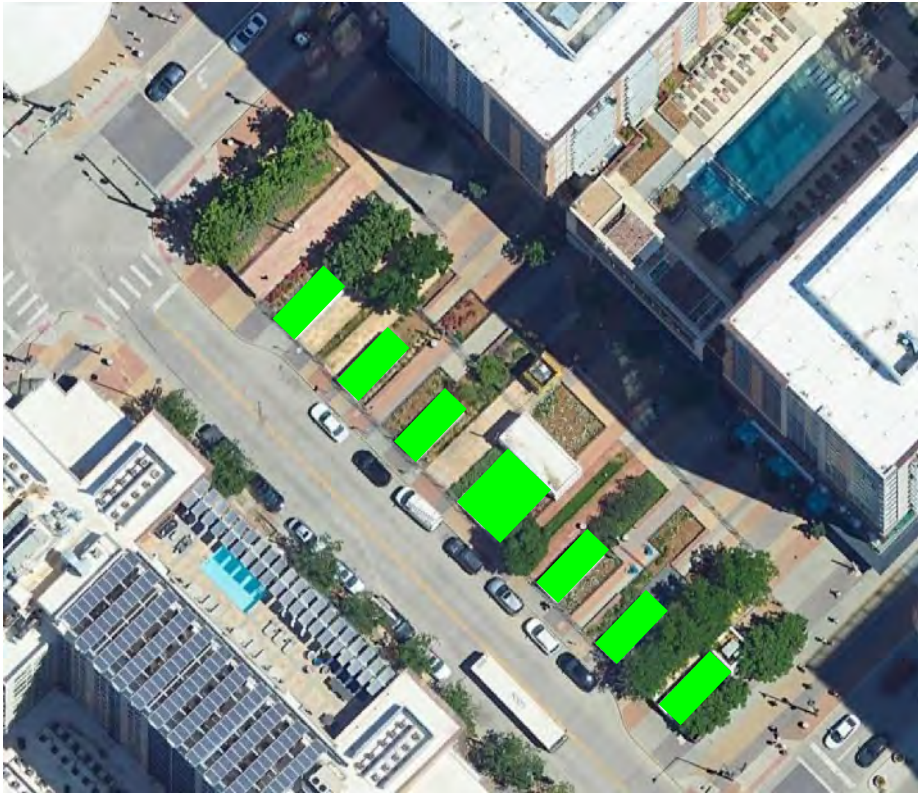

Another great opportunity for creativity is to place these grazer lights below the tunnel skylights to illuminate the garden above with a playful light show. The windows would need an adhesive treatment applied to ensure the even transmission of light throughout the glass. Additionally, these fixtures would communicate with our Pharos controls, enabling the entire lighting environment to be operated from a single system.

Video Link:

<https://www.environmentallights.com/news/architectural-led-lighting-detroit-skybridge.html>

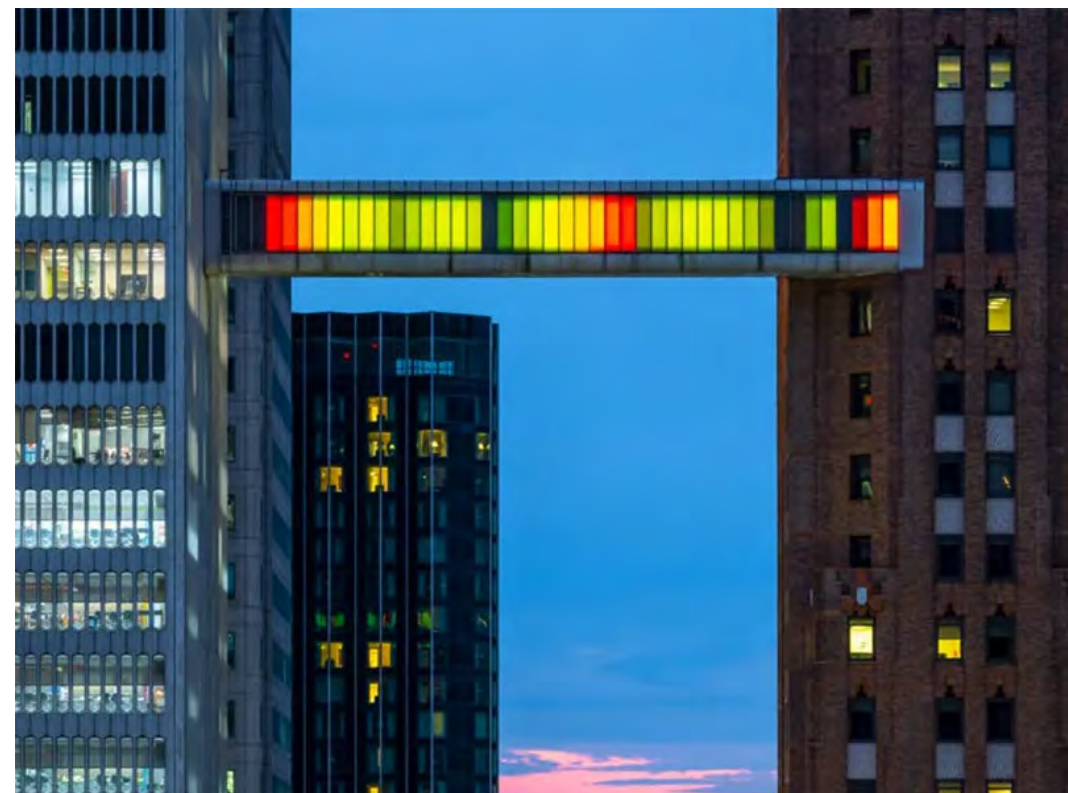

Inspiration photos

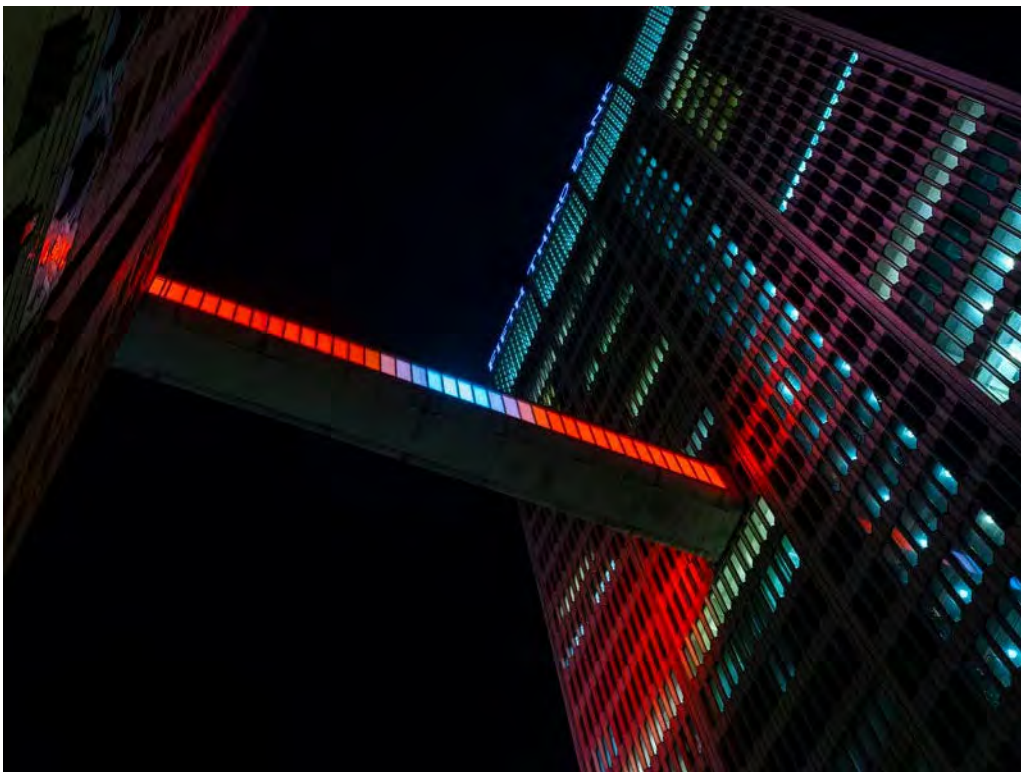

LINEAR GRAZE / SĚNIK GRAZE LĪT



SĚNIK GRAZE LĪT RGBW

1ft Outdoor Linear Graze

The SĚnik Graze LĪt is a sleek and versatile solution to all architectural graze lighting applications. Features of system include 180° pre-attached adjustable mounting brackets, output of over 1200 lumens per foot, and IK06 impact rating. Plug and play 6-pin wiring system is convenient and efficient for installer. With additional visor accessories to minimize discomfort glare, the SĚnik Graze LĪt offers the utmost in efficiency and minimalism.

- RGB + 3000K white standard
- 35° and asymmetric 20°x45° optics available for tailoring light to application
- Over 500 lumen output per foot (all channels on)
- Extruded aluminum housing & die-cast accessories
- Custom 180° adjustable mounting brackets are laterally adjustable along extrusion
- Satin aluminum finish (black, white, and custom RAL available special order)
- cETLus Listed, IP66 (wet location)
- Optional asymmetric and symmetric anti-glare visors available
- L70>70,000 hours rated life

PROJECT: _____

TYPE: _____

LOCATION: _____

CATALOG NUMBER: _____



SĚNIK GRAZE LĪT RGBW QUICK SPECS

VOLTAGE	100-277V AC
MAX POWER	12W
POWER FACTOR	>90 (@100V)
LUMENS	Up to 552 lumens (all channels on)
CCT OPTIONS	RGB + 3000K
CRI	80+
MOUNTING	Surface mount
DIMMING	DMX512-RDM
OPTICS	35° 20°x45°
MAX POWER LINK	70 units (@100V) 196 units (@277V)
MAX SIGNAL LINK	30 units (@100V) 30 units (@277V)
MAX RUN LIMITATION (VOLTAGE DROP)	Ensure a single, continuous run from power input to termination does not exceed 50m (164') @100V AC or 75m (246') @277V AC (includes lead wire, fixtures, and jumpers). Must reinject power (PZM-WGL-6TCON) when exceeding 50m (164') @100V AC or 75m (246') @277V AC.
OPERATING TEMP	-40°F to 122°F (-40°C to 50°C)
IP RATING	IP66
IK RATING	IK06
CERTIFICATIONS	cETLus Listed - Wet Location
RATED LIFE	L70>70,000 hours

If these ideas are well received, our next steps would be to identify the exact locations and number of fixtures needed. Once that is identified, we can work with CPV's preferred electrician or refer one that we work with to provide an estimate for installing power to the required locations.



SSWW-39
Snowflake Arch (A.) 31 ½' x 19'



SSUA-3
Jolly Snowman 17' x 12'



SSWW-81
Winter Lights Arch 45' x 24 ½'



SSWW-14
Leaping Deer Arch (A.) 38' x 25'



SAR-500
Celestial Arch 8' x 11'



SSLF-6
Wreath Portal Arch 40' x 26'

2024 Holiday Lighting Design Ideas Comparison
Central Platte Valley MD

Contractor	Details	Total Cost	Application in CPV
Amazon Options	<ol style="list-style-type: none"> 1. (6) Solar Christmas trees 2. (4) 3-packs of solar starburst sphere lights 3. (2) 4-packs of solar string lights (10) changing curtain lights 	<ol style="list-style-type: none"> 1. ~\$360 2. ~\$184 3. ~\$44.18 ~\$245.90	<ol style="list-style-type: none"> 1. Throughout District 2. Throughout District 3. On Gardens trees In windows of businesses/buildings within District or surrounding the Gardens
CREOS	<ul style="list-style-type: none"> • Experience working in Cherry Creek BID • One large transport from Montreal • Turn-key exhibits using low power and can stand alone (no monitoring or maintenance) • Can troubleshoot from a distance • Can tap in land posts for power • Can display for 4, 6 or 8 weeks 	“The Tunnel” = \$74,264.39 “Optik” = \$79,557.35	In the 17 th Street Gardens
Display Devices	<ul style="list-style-type: none"> • Moving, dynamic projections which can be monitored remotely and/or holiday arches • General conversions: \$1,000/minute for content and \$1/lumen • Infrastructure can be rented or bought for long-term use • Services include electrical, permitting, project management and installation 	Estimated between \$750,000 and \$1.5 million	On the sidewalks on each side of the 17 th Street Gardens and inside the 17 th Street Gardens